



Broadcast Devices, Inc.

Technical Reference Manual

***SWP-300- Site Controller with Instructions  
For Use with the DPS-100D Power Monitor System***

**READ THIS MANUAL IN ITS ENTIRETY BEFORE ATTEMPTING  
INSTALLATION**



**Broadcast Devices, Inc.**

**Tel. (914) 737-5032**

**Fax. (914) 736-6916**

**World Wide Web: [www.Broadcast-Devices.com](http://www.Broadcast-Devices.com)**

**Rev B. – 3/18**

**SWP-300-1/2T Firmware 3.9.23 and higher Serial # 103 and higher  
DPS-100D Firmware 1.2.002 or higher**

## Table of Contents

<b>I.</b>	<b>Introduction</b>	<b>3-4</b>
<b>II.</b>	<b>Unpacking and Inspection</b>	<b>4</b>
<b>III.</b>	<b>Installation and Connection</b>	<b>5-12</b>
<b>IV.</b>	<b>Rack Installation of SWP-300 Chassis</b>	<b>13-14</b>
<b>V.</b>	<b>Programming Features and Operation of the SWP-300</b>	<b>14-24</b>
<b>VI.</b>	<b>Control Output 1-8 Connections</b>	<b>24</b>
<b>VII.</b>	<b>Status Inputs 1-8 Control Outputs 9-16</b>	<b>25</b>
<b>VIII.</b>	<b>J2 A/D IN/TX VSWR FLT. STATUS</b>	<b>25-26</b>
<b>IX.</b>	<b>Communications Interface Information</b>	<b>26-29</b>
<b>X.</b>	<b>Specifications</b>	<b>30</b>
<b>XI.</b>	<b>Warranty</b>	<b>31</b>
<b>XII.</b>	<b>Motorized RF Switch Interface Diagrams</b>	<b>32-36</b>

## I. Introduction

This technical manual covers the installation and configuration of the Broadcast Devices, Inc. **SWP-300 Site Monitor/Motorized Switch Controller Chassis** and its connection to the Broadcast Devices, Inc. **DPS-100D** Power Monitor System. An accompanying DPS-100D Technical Reference Manual is supplied with each system. Please refer to the DPS-100D Technical Reference Manual for operation and setup of the DPS-100D system.

The SWP-300 System family of controllers is designed to simplify the connection and operation of 4 port switches in broadcast applications and provide additional control and status inputs for general remote control functions. Like its SWP-300 series product companion the SWP-300 is designed to control and sequence switches and transmitters to provide safe and reliable control of the transmitter plant. In addition there are 8 relay outputs, 8 solid state outputs and 8 status inputs. The SWP-300 automatically “steers” the interlock connections to the transmitters according to the position of the RF switches. The power meter section of the system provides RMS forward and reflected power indication suitable for analog FM, digital power measurement such as needed for in band, on channel broadcasting, DAB and digital television 8 VSB/DVB modulation techniques.

The SWP-300 is an intelligent controller which may be connected to optional BDI DPS-100D RF sensors to provide additional functionality and safety. When equipped with BDI DPS-100D series RF sensors, the SWP-300 “Switch Saver” will detect and prevent an attempt to move a switch while RF is present to prevent damage to the switch and/or other equipment.

The SWP-300 provides both forward and reflected power display for a main and auxiliary sensor channel as well as reflected power protection via a proprietary “three strike”™ algorithm contained within the DPS-100D power sensor if supplied. This algorithm prevents the SWP-300 from responding to transient events such as close-by lightning strikes and avoids unnecessary off-air incidents.

In addition, the SWP-300 via the DPS-100D power sensor is capable of detecting a drop in RF power below a user configured threshold and automatically switching to backup transmitter. Dual switch versions of the SWP-300 are capable of responding to a reflected power fault by automatically moving to a backup antenna.

The SWP-300 along with the DPS-100D series power meters act as SNMP V2 agents. The SWP-300 and DPS-100D can be used with any standard MIB browser or SNMP enabled remote control for access to control and status information. The MIB files associated with these products are contained on the

BDI Product Data CD supplied with each unit. The MIB files can also be downloaded from our ftp site.

### ***Basic Description of models:***

**The SWP-300-1 Series** controls one - two position switch assembly.

Basic single switch controller/site controller for controlling up to two transmitters connected to up to two loads, typically an antenna and dummy load. – Optional RF sensors available for “Switch Saver”™ operations, auto switching upon power loss and VSWR 3 strike protection. Provides 8 relay outs with NC/C/NO, 8 solid state outputs, and 8 status inputs. Also provides local control of TX Off/On, TX select, TX Interlock Status, and fault reset/status, Auto/Manual Command/Status and 4 analog inputs for legacy equipment.

**The SWP-300-2 Series** controls two – two position switch assemblies. - Optional RF sensors available for “Switch Saver”™ operations, auto switching upon power loss and VSWR 3 strike protection, VSWR detection for switch operation to a standby antenna. For two switch controllers connect SWITCH 1 rear panel connector to switch that will select transmitters and SWITCH 2 to the switch that will select antennas. Provides 8 relay outs with NC/C/NO, 8 solid state outputs, and 8 status inputs. Also provides local control of TX Off/On, TX select, TX Interlock Status, and fault reset/status, Auto/Manual Command/Status and 4 analog inputs for legacy equipment.

## **II. Unpacking and Inspection**

Carefully inspect the unit after unpacking and make certain that no damage has occurred during shipping. If damage is noted, contact the shipper immediately and file a claim for damages. Each unit is carefully packed and carries full insurance against damage. Inspect the packing list and make sure that the contents of the package match those described on the packing list.

## **III. Installation and Connections**

### **Wiring Considerations:**

The SWP-300 has the capability to totally automate the control of transmitters and switch operations with the touch of a button. The units have provision to turn transmitters off/on and provide interlock closures. Some applications may require separate transmitter off and on control in addition to interlock closures managing transmitter on/off functions. The contacts are provided for both. Some installations may call for interlock connections only to turn transmitters on and off. It is entirely up to the installer. The flexibility of both methods has been designed in to the SWP-300 series controllers.

## Basic Wiring Methodology

Refer to SWP-300 REMOTE COMMAND/STATUS Connector and Remote Antenna Select Remote Control Connects drawing page 9 for the following discussion.

The SWP-300 is capable of turning on the air selected transmitter after switch movement if the TX ON button was previously pressed or TX ON command was initiated by remote control.

Interlock inputs are provided for each position of both switches on DB-15 connectors shown on page 11 to assist in wiring the interlock string for each mode. Connect any interlock switches associated with each mode in series between the pin associated with that mode and a control/status common pin. The SWP-300 automatically “steers” the interlock connections to the transmitters according to the position of the RF switches. Refer to page 15 for a diagram illustrating interlock steering. **FAILURE TO MAKE CONNECTIONS TO THIS CONNECTOR WILL RESULT IN NO INTERLOCK CLOSURE OPERATION OF THE TX 1 and TX 2 INTERLOCK RELAYS! If no external interlock paths exist simply place jumpers across the pins shown on page 12 – External Interlock connector.**

**A. SWP-300-1/2 Install the unit in a suitable EIA rack enclosure.**

***As a safety precaution, never install a switch controller to a switch system that has radio frequency energy present on it or where AC/DC control power is applied. This can be dangerous and can easily damage a switch!***

1. Before applying power to the SWP-300-1/2 or to the switch assembly, connect the supplied DB15 connector to the motorized switch plug or strip connector cable. Refer to section IX typical Switch Connections Diagrams section for suggested wiring details for most motorized switches available. If you are attempting to interface a switch assembly not covered in this section please contact the factory for assistance with your switch assembly. The DB15 connection plugs into the SWP-300 “SWITCH 1 and/or 2” connector inputs on the rear of the unit. These connections are the only connections to the switches required except for electrical power. Control of the switches, position status and interlock control are all handled by these cables. Additional switch position and/or interlock connections may be available on the respective manufacturer’s switch connector if desired for some other use.

2. Next, apply power the SWP-300 and observe the front panel. If all connections are made properly and the switches are correctly seated in positions A or B, the front panel display should indicate the present position of the switch assemblies. If the switch assemblies are not connected properly or are in the middle of their

travel, the front panel will indicate “Check Switch 1 (2) “Both”. In this case check that the switches are seated properly by applying A.C. power to the switch(es). If a switch is in mid travel it will go to the position that the switch internal latching relay commands it to be in. Recheck the SWP-300 display for proper position indication. If the SWP-300 still shows “Check Switch” then the most probable cause is a defective interface cable or a problem with the switch electronics.

**Note for SWP-300 use without a motorized switch:**

**For installations where the SWP-300 will be used for power measurement only where no motorized switch is to be connected it is necessary to place a jumper across pins 6 and 14 of the “Switch 1” connector. Use one of the provided DB15 connectors for this purpose. Failure to do this will result in a “Check Switch 1” indication on the display.**

3. Make remote control, status, and transmitter control connections to SWP-300 rear panel remote control connector according to tables/connector diagrams on pages 7, 8 and 9. Note that the common connection for command and status is ground. The interlock connections are dry contact relays with 24 VDC 3 Ampere contact ratings which can be interfaced to an external interlock as desired.

### **Frequently asked Questions including Interlock Relay Operation:**

**Question 1:** How do the SWP-300 interlock relays function?

**Answer 1:** The SWP-300 system is designed to be a “failsafe” system. This means that the SWP-300 and/or DPS-100D power sensor provide interlock closures only when the SWP-300 has electrical power and the conditions in answer 2 are met below. This means that the SWP-300 will drop your interlocks if power is removed from the SWP-300 chassis or the SWP-300 fails. Failsafe by definition means that failure of the “system” designed to protect life and/or equipment must fail in a **safe** way. If the SWP-300 and/or DPS-100D power sensor fail they can no longer protect your transmission system from damage and therefore shut down your transmitter. Consider that a bit of lost air time is a small price to pay compared to a high VSWR condition causing thousands or tens of thousands of dollars’ worth of damage to your transmission line and or transmitter. In addition consider the cost of lost air time while you are waiting for a new transmission line to be installed.

**Question 2:** Which set of contacts should I use, normally open/common or normally closed/common?

**Answer 2:** It depends on your transmitter manufacturer specification. Most manufacturers require a closure between their “external interlock” connections for the transmitter to operate. If this is the case with your transmitters then you need to connect the external interlock connection of the transmitter to the **normally open** and **common** connections on SWP-300 J7 – TX. CTL/INTERLOCKS. Here

is why. With all connections made to the SWP-300 the SWP-300 will provide interlock closure on the normally open/common (relays energized) connections provided that:

1. Any DPS-100D power meters are properly connected and communicating with the SWP-300 chassis and that the EXT interlock jumper or path is closed on the DPS-100D sensor. This connection can be found on positions 11 and 12 of the 12 position Phoenix connector on top of the DPS-100D sensor. Proper closure is indicated if when viewing the DPS-100D sensor there is no icon showing under the LOTO indication. If a padlock icon is showing on the DPS-100D display there is no interlock closure and should be investigated. If no DPS-100D meters are connected then the main/aux power sensors should be disabled from the SWP-300 front panel menu. See page 16 for instructions on how to enable/disable DPS-100D Sensors.
2. All external interlock connections are made to the SWP-300 rear panel DB 15 connector labeled EXT. INTERLOCK 1 or 1 and 2 if a two switch controller is installed. **THESE CONNECTIONS MUST BE MADE OR THE INTERLOCK RELAYS WILL NOT CLOSE. SEE PAGE 11 for CONNECTION INFORMATION. EVEN IF YOU HAVE NO EXTERNAL INTERLOCK PATHS YOU MUST PLACE JUMPERS ON THE APPROPRIATE PINS DESCRIBED ON PAGE 11.**
3. The motorized switch is properly connected to the SWITCH 1 or SWITCH 1 and 2 SWP-300 DB-15 connectors. Check for proper front panel status of each position of the switch by manually moving the switch to each position. If the switch does not provide proper status you will see a CHECK SWITCH indication on the front panel. Recheck your wiring or the switch itself for proper operation.
4. Power is applied to the SWP-300 chassis and DPS-100D if installed.

**Question 3:** Can I use the SWP-300 as a remote control?

**Answer 3:** The SWP-300 is designed to turn on and off the transmitter selected to air, switch between main/aux. transmitter and to provide RF power metering and status of the on air transmitter. If a DPS-100D power meter is attached and optional sensors installed status is available including temperature and transmission line pressure. The SWP-300 also provides 8 relay control outs, 8 solid state outs, 8 status inputs and 4 analog inputs. For most applications this amount of control and monitoring is sufficient for proper plant operation so the answer is yes you can use the SWP-300 as a remote control. There are several ways in which you can access the SWP-300 remotely:

1. Through the use of BDI's free BDI Stack - graphical user interface it is possible to connect to the SWP-300 web interface directly. The GUI is available for download from our web site under software.
2. The SWP-300 can be used as a secondary remote control for backup

purposes. Through the use of J1/J5 SW local Control/Status connectors for legacy remote controls or via SNMP for newer remote controls the SWP-300 can be interfaced to a second remote control if desired. If the primary remote fails the SWP-300 can be accessed via the GUI for control and status information.

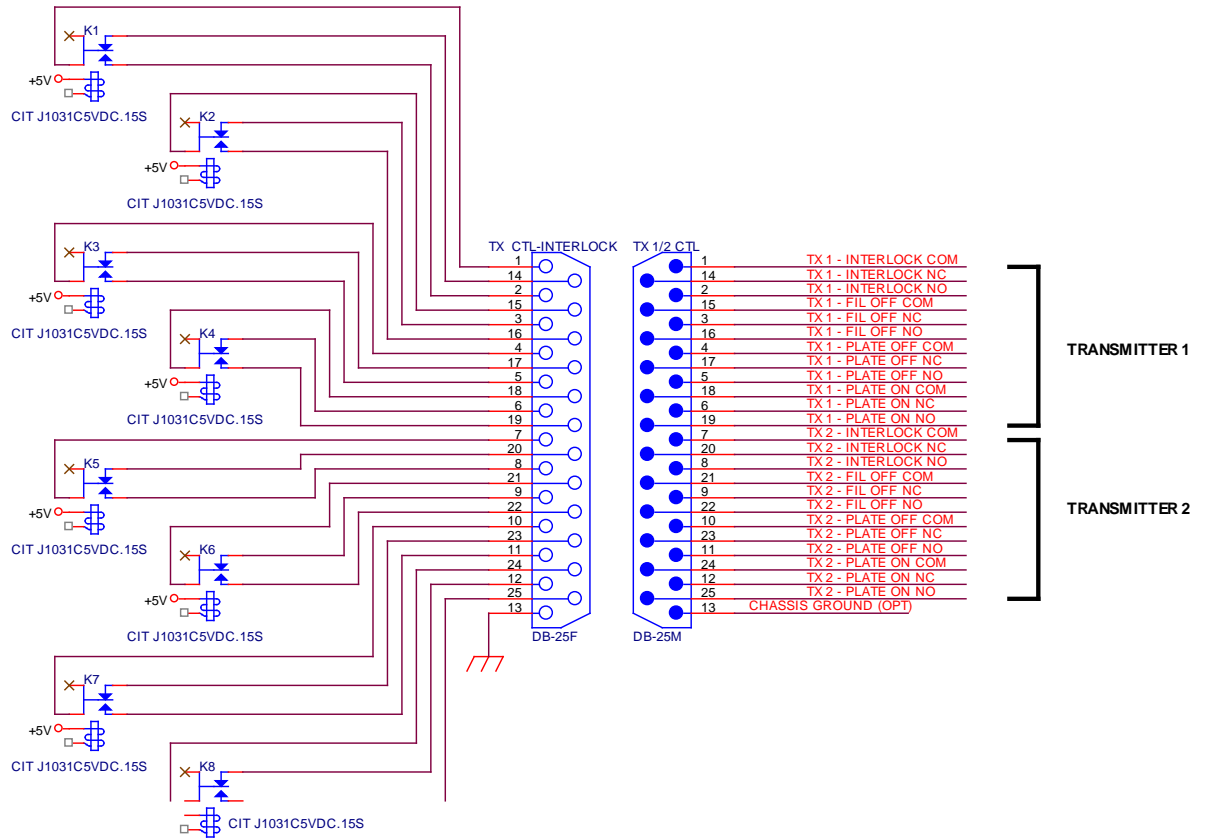

**J7 TX CTL/INTERLOCKS DB-25 Pin Connection Diagram**



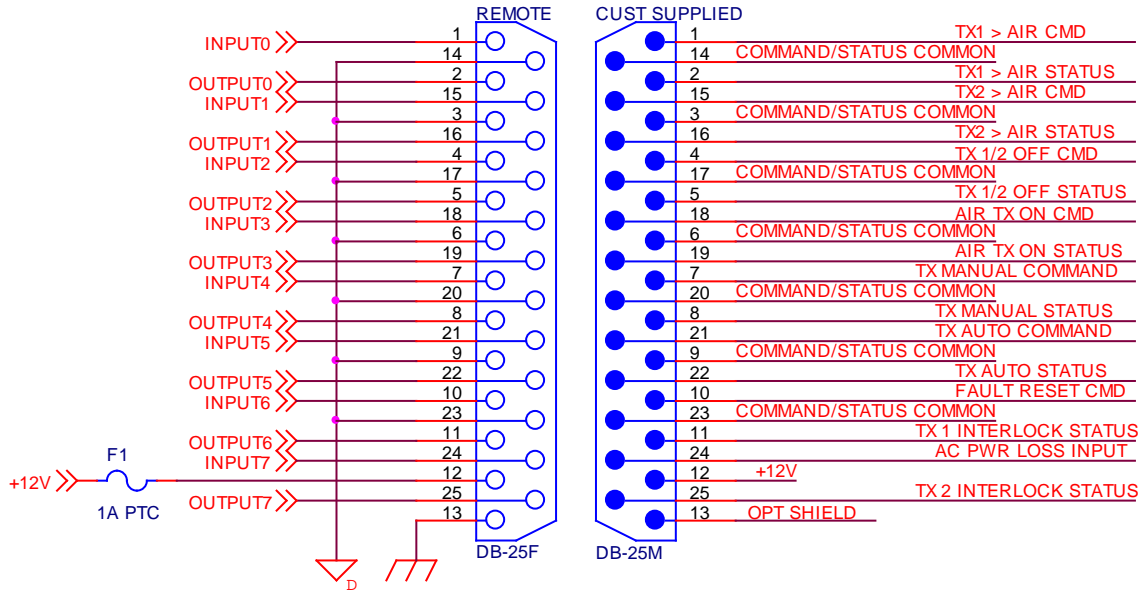

**J1 Remote Command/Status DB-25 Pin Connection Diagram**

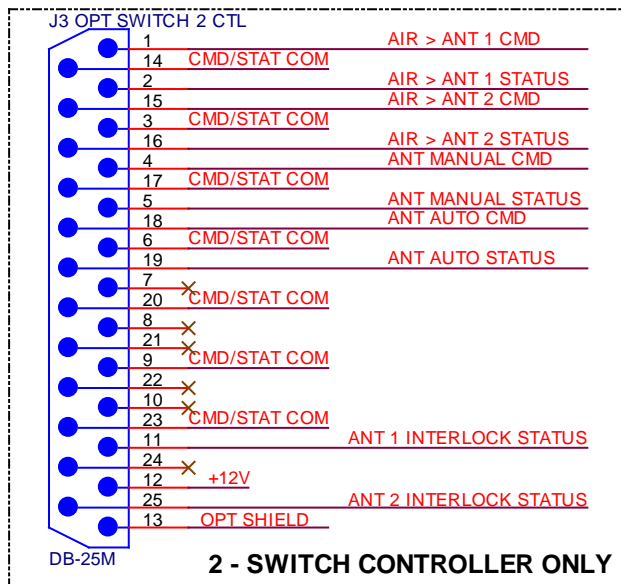

**J5 SW2 Local Control/Status Connector**

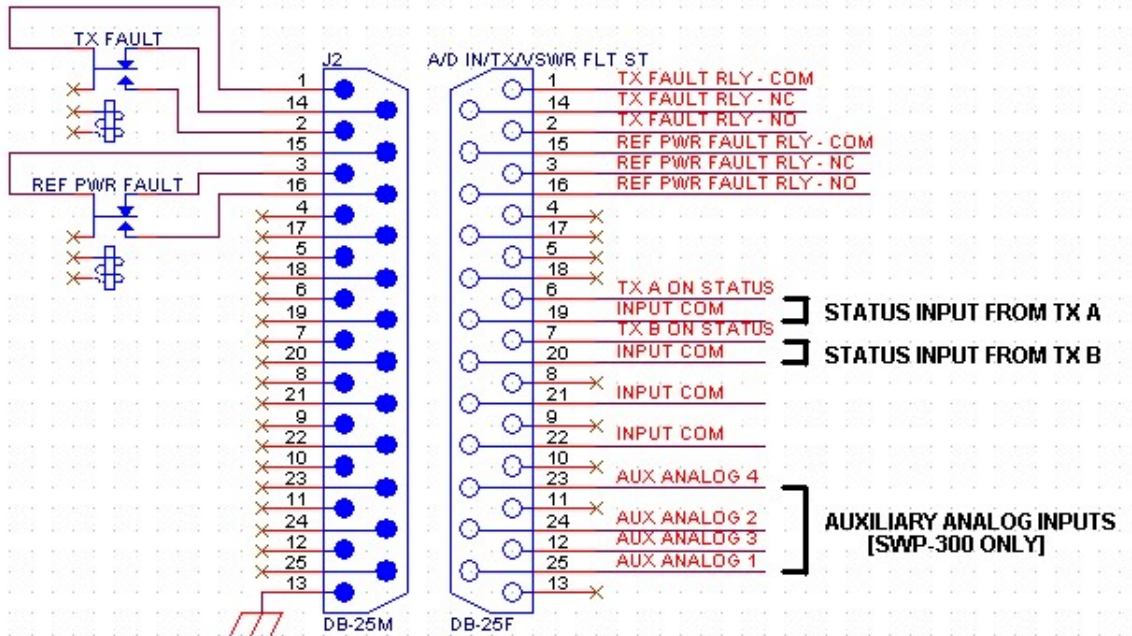

## J2 A/D IN/TX/VSWR FLT ST. Rear Panel Connector

J2 Status connector provides status of when a low power or no power fault has caused the SWP-300 to initiate an auto switch of transmitters and/or when a high reflected power condition has caused the SWP-300 to initiate a 3 strike lockout of transmitter interlocks. Connect as desired to a status input on remote control systems or local status panels. There are also inputs provided for TX 1, 2 TX ON status. This provides positive status that a transmitter is on when commanded to come on. A “low” logic level or connection to status common will provide “ON” status for the designated input. The TX1/2 ON inputs will provide status on the BDI Stack GUI of transmitter operation.

## Interlock Path Connectors – “External Interlock” connectors 1, 2

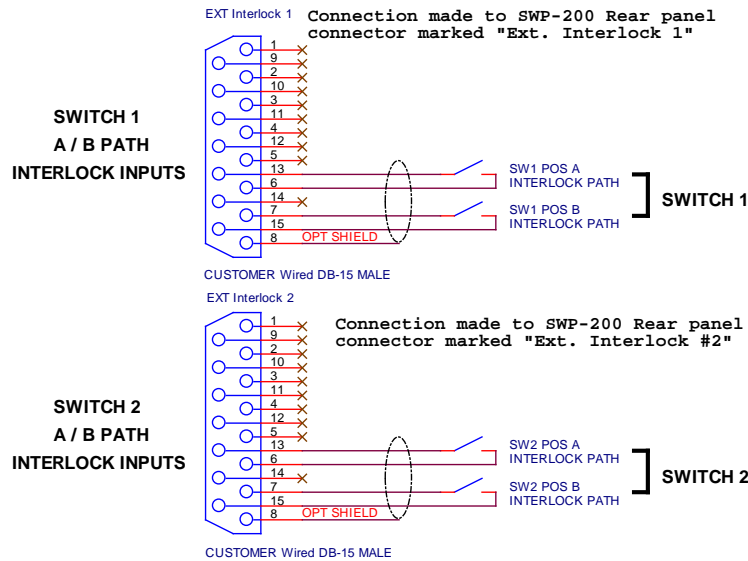

22 AWG CABLE RECOMMENDED

### NOTES:

1. TRANSMITTER INTERLOCK PATH WILL BE CLOSED WHEN CORRESPONDING SWITCH INTERLOCK INPUT PATH IS COMPLETED.
2. IF PATH IS NOT REQUIRED, JUMPER INPUT ON CONNECTOR.

**For SWP-300-2T two switch models connect switch 1 connector to the switch that will select transmitters and switch 2 to switch that will select antennas.**

## DPS-100D Power Meter/Directional Coupler Installation and Interconnection with the SWP-300 chassis

1. Determine a suitable location for the supplied EIA flanged precision directional coupler. The coupler should be placed in the load path such as the antenna or in the case of a dual coupler system a dummy load path. Note RF direction indication on the directional coupler and install accordingly.

The SWP-300 Site Controller can display data from up to 2 DPS-100D Digital Power Sensors in a single rack unit display. The SWP-300 measures 2 - directional coupler forward/reflected outputs simultaneously providing interlock control to safeguard against damage caused by high reflected power. The SWP-300 displays the forward/reflected power, temperature and line pressure measurements from the DPS-100D. These indications are available on the BDI Stack GUI. So no additional analog inputs are needed for this purpose.

## **Description of DPS-100D/SWP-300 Site Controller System**

The SWP-300 Site Controller series protection system has been designed to communicate with the DPS-100D RF Power sensor. A single CAT 5 cable interface to up to two DPS-100D sensors can be supported. RS485 communication protocol allows for addressing of each sensor.

### **DPS-100D Installation Considerations**

Each DPS-100D directional coupler/sensor should be placed in the desired location for measurement. Each supplied directional coupler has a set of measurement ports, one for forward power and the other for reflected power. There is also provision for external temperature and line pressure sensors. Each DPS-100D has an internal temperature sensor for measurement of internal electronics temperature. These indications will be available in three places: 1 – the DPS-100D on board display, 2 – the SWP-300 Site Controller LCD display and 3 - via a web server connection and the BDI Stack GUI. Refer to the accompanying DPS-100D Technical Reference Manual for complete operating instructions and set up of the DPS-100D. This section of the SWP-300 manual is intended to give the installer and operator information on interconnecting the two products.

1. Install the coupler making sure that the flow of RF follows the arrow direction marked on the coupler. Failure to do this will provide erroneous power indications as they will be reversed.
2. Using standard CAT 5 cable attach a cable from the rear panel of the SWP-300 chassis using the supplied DB9 to RJ45 adapter. This adapter should be plugged in to the DB9 connector marked RS485. Connect the other end of this cable to the first DPS-100D RJ45 receptacle marked RS485. Note that each DPS-100D sensor has two RJ45 receptacles marked RS485. The second connector is used to connect to the next DPS-100D sensor or in the case of only one sensor a supplied RS485 terminator is connected to properly terminate the RS485 bus.

#### IV. Rack Equipment Location and Connection of SWP-300 Site Controller

1. In a suitable EIA 19" rack enclosure mount the SWP-300 chassis. ***It is strongly recommended that the SWP-300 be plugged into a personal computer style UPS system if the system is to be used where interlock control of broadcast transmitters is contemplated.***
2. Attach the supplied DB9 to RJ45 adapter to the rear panel DB9 connector marked RS-485 on the SWP-300 chassis.
3. Using the supplied Ethernet cables attach one Ethernet cable to the RJ45 receptacle of the adapter installed in step 2 to the first sensor in the system. Using supplied cable daisy chain attach from the first sensor to the next if supplied. Each DPS-100D sensor has been supplied with its own RS485 address 1 or 2. The data for each sensor will appear on the respective SWP-300 channel main or auxiliary. Main is address 1 and auxiliary is address 2. Note that when the DPS-100D sensors are used in conjunction with the SWP-300 chassis they are powered through the RS-485 connection. **Do not use the external power jack on the DPS-100D when used with the SWP-300 chassis.** Make sure all connections are complete and all DPS-100D sensors show an active display. The RS485 address of each sensor is programmed at the factory but it is possible to change this address if desired. To perform this change consult the DPS-100D Technical Reference Manual supplied with the DPS-100D sensor. NOTE: No two DPS-100D sensors can have the same RS-485 address or the system will fail to operate properly. See Fig. 1 below

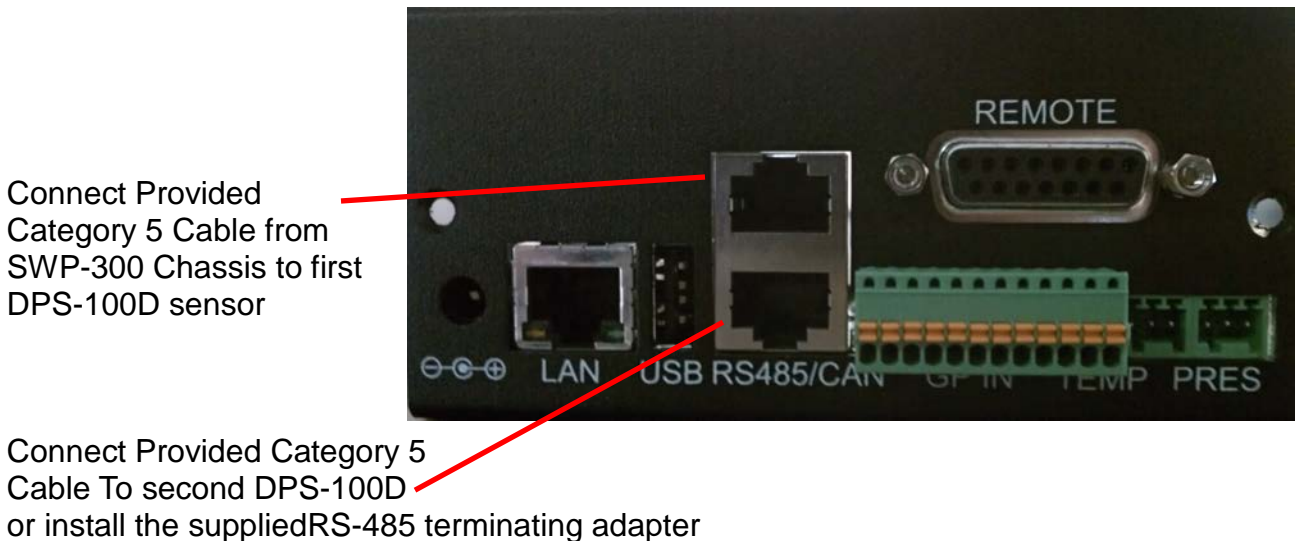

**Fig. 1 Shows connection from SWP-300 Chassis and to succeeding DPS-100D Sensors or termination if only one sensor is supplied.**

4. Once all DPS-100D sensors have been connected their local displays should be lit and should display the normal operating screen which shows Forward/Reflected Power, Temperature, Pressure and other data. Note that when properly connected and addressed the SWP-300 channels will show power indication. For channels where no sensor is present but enabled as described on page 17 under section V. Programming Features the power indication will be a series of dotted lines indicating no data available. This will happen for one of two reasons. A connected sensor for that channel is not communicating with the SWP-300 chassis or it is programmed on the wrong RS-485 address. To verify and adjust the RS485 address for the DPS-100D sensor refer to the DPS-100D Technical Reference Manual for instructions. If no sensor is attached for that channel and the dotted line indication is shown for that sensor go to the setup menu as described on page 17 and select Sensor 1 or Sensor 2 and disable it. If for some reason a desired channel is not showing data when connected to a DPS-100D sensor, check the cabling to make sure it is seated properly and check the display ICON under COMMS. Review Fig.2 Also make certain that the RS485 address is set properly for all connected sensors.

Communications Icon  
Indicating RS-485  
Communications established with  
SWP-300 Chassis



**Fig. 2**

### **Optional Connections:**

When the optional BDI TMP-100 temperature and PSW-100-5 pressure sensors are attached to the DPS-100D RF sensor a complete set of data including forward/reflected power, temperature and pressure can be displayed on the SWP-300 chassis for the respective DPS-100D channel. Normal operation of the SWP-300 chassis displays forward/reflected power. To access the temperature and pressure readings use the left/right arrow keys to access the screen indicating temperature and pressure. Of course forward/reflected power, temperature and pressure indications are available through the BDI Stack GUI as well.

**BDI TMP-100** can be attached to any DPS-100D. The DPS-100D provides power for the sensor. A three position plug is supplied with each TMP-100 for direct plug in to the DPS-100D sensor

**BDI PSW-100-5** Pressure sensors can be connected in a similar fashion to the temperature sensor described above.

Temperature and pressure can be monitored from the front panel of the SWP-300 by advancing the left arrow key until the temperature and pressure screen appear. Temperature and pressure indications are also available via the communications interface. The free BDI Stack graphical user interface available from [www.broadcast-devices.com](http://www.broadcast-devices.com) can be used to remotely display all SWP-300 parameters over the public internet see section VI. for more information.

### **V. Programming Features and Operation of the SWP-300 Site Controller Chassis**

The SWP-300-1T is preprogrammed for single switch operation and requires only minimal programming. The SWP-300-1T is factory configured to switch between 2 transmitters.

To enable full functionality of the enhanced features a number of parameters must be configured during the installation process. All programming can be accomplished from the front panel.

To enter the programming menu, press the green CHECK MARK key in the center of the keypad. Pressing the CHECK MARK key again will exit the programming mode and save all settings which were modified. Pressing the red X key will exit the programming menu and discard all changes.

Once in the programming mode pressing the LEFT or RIGHT arrows will sequence through the list of programmable parameters. Pressing the UP or DOWN arrows will sequence through the available options for the currently

displayed parameter.

The following parameters are user configurable:

**Local/Remote** – In the remote position allows the unit to accept commands from both J1 Remote Control connector inputs and web interface remote control. In the local position the unit will respond only to front panel commands.

**Auto Switching** – Enable/disable automatic backup transmitter switching based on RF power level. If auto switching is enabled an “A” will displayed in the lower left corner of the display. If auto switching is disabled, an “M” will be displayed.

**Auto Return** – Enable/disable automatic return to the main transmitter if the backup transmitter fails to turn on or if the backup transmitter power is less than the Auto Switch Level. If the SWP-300 executes an Auto Return, it will enter the Manual mode to prevent undesirable subsequent switching operations. If auto return is enabled, an “R” will be displayed to the right of the auto switch indicator while auto switch is enabled.

**Auto Antenna Switch Mode** (Two Switch Models Only) when enabled will transfer the selected transmitter to the auxiliary antenna when a high reflected power condition above the threshold set in the DPS-100D menu. To enable this function enter programming menu and use left/right arrow keys to navigate to the selection Auto ANT SW = On/Off. To select on mode press the up key the down key to select off. This mode can only be entered if RF power is applied to the system.

**Auto Switch Time** – Sets the amount of time that the main transmitter must remain below the user configurable level before the SWP-300 will switch to the backup transmitter.

**Auto Switch Level** – Configures the level at which the SWP-300 will automatically move to the backup transmitter.

**Sensor 1 (MAIN) Enable/Disable** Enables or disables main sensor. This is normally set at the factory but for troubleshooting purposes or in the event of a sensor failure the disable feature allows the user to use the SWP-300 without sensors connected.

**Sensor 2 (AUX) Enable/Disable** - Enables or disables aux. sensor.

**Serial Remote Control Enable/Disable** – This menu item allows the operator to either enable or disable serial and/or remote LAN remote control of TX ON/OFF, SWITCH CONTROL, ERROR RESET functions. If enable is chosen, remote control of these functions is allowed through the remote LAN interface to the BDI Stack GUI. If serial control is disabled the SWP-300 can still provide status via



the BDI Stack GUI but no remote control of the unit will be possible.

**Basic Theory of Operation:**

Upon front panel or remote control command the SWP-300 operation sequence is as follows:

1. Command from the CPU board is issued to the transmitter control/interlock board to issue a PLATE OFF/TX off commands and open the safety interlocks of both transmitters connected to the four port switch.
2. Approximately 2 seconds after these commands are issued the SWP-300 issues a switch command to the appropriate pin of the SWx I/O interface connector.
3. Once the switch reaches its commanded position the SWP-300 receives new position information from the switch via the SWx I/O interface connectors and issues an interlock closure command. Approximately 2 seconds later the chosen "Position relay" closes and then issues a Plate On/TX "ON" command to the transmitter feeding the on air position. The SWP-300 connects the correct A/B interlock path inputs to the transmitters for the path they are feeding. The circuit shown below is typical of what may be encountered a typical installation. If no additional interlock connections are needed simply connect the respective A/B interlock inputs to common as shown on page 12 External Interlock connections.

**INTERLOCK STEERING - TX1 ON AIR**

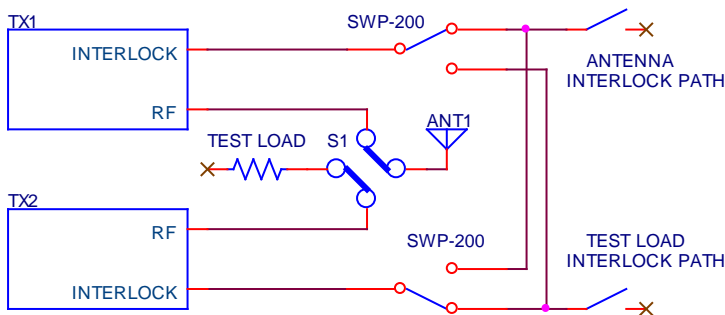

**INTERLOCK STEERING - TX2 ON AIR**

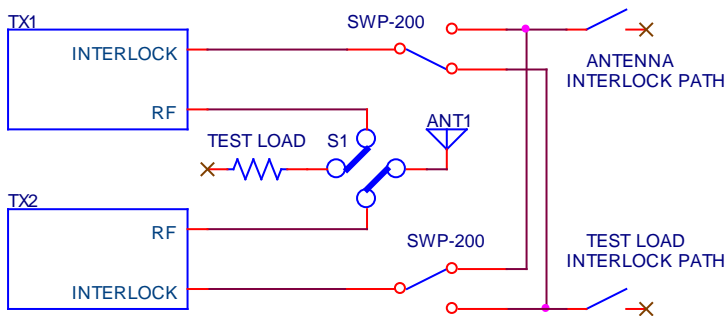

Note: If the 4 port switch fails to reach the commanded position due to

mechanical or power failure, the SWP-300 will hold the interlock connections in the open position and will not issue a TX “ON” command.

The SWP-300 will reflect the actual position and status of the four port switch. If it becomes necessary to manually move the four port switch to a new position the SWP-300 will sequence the interlock and other transmitter control relays as from a front panel or remote control command to the SWP-300.

### **CAUTION!**

**Certain motorized switch manufacturers offer switches that when manually moved with the AC power removed will revert back to the previous position when AC power is reapplied. This NOT the SWP-300 commanding the switch. Due to the use of magnetically latching relays in some manufacturer’s products they will “remember” the last position commanded and move to that position. It is not recommended to disconnect the SWITCH ½ connector(s) from the rear of the SWP-300 during manual switch operation. In addition power must be applied to the SWP-300 for proper interlock action when manual switching is performed. Transmitters should be turned off otherwise the risk of moving a switch with RF applied may occur. ALWAYS TURN TRANSMITTERS OFF AND DISABLE THEM WHEN IT IS DESIRED TO MOVE A SWITCH MANUALLY.**

### **Switch-Saver RF sensing:**

***This function requires an optional DPS-100D RF power sensor installed***

The SWP-300 (when equipped with RF detection) will examine the RF level present on the switch to prevent movement of any switch when RF is present. This prevents damage to a switch or other equipment due to incorrect/damaged transmitter interlock connections or transmitter malfunction. ***The Safe Switch Level configures maximum level that may be present for the SWP-300 to allow manual or automatic movement of a switch. While this level can be changed by the user, we do not recommend increasing the level above the default 1 W level without consulting with the factory prior to such a change.***

## **Automatic Transmitter Switching:**

***This function requires an optional DPS-100D RF power sensor installed.***

The SWP-300 automatic transmitter function can (if enabled) switch a backup transmitter to the air antenna when the RF power from the currently selected air transmitter falls below the user configured TX Auto Level. The TX Auto Time parameter sets the delay during which the SWP-300 will wait for the power to return to a level above the TX Auto Level before initiating an automatic switching operation. When the RF power of the air transmitter drops below the TX Auto Level (user configured) for longer than the TX Auto Time (user configured) the SWP-300 will execute the transmitter turn off sequence, connect the other transmitter to the air antenna by moving SWITCH 1 to the alternate position and subsequently executing the air transmitter turn on sequence. If the TX Auto Return function has been enabled by the user, the SWP-300 will monitor the RF power level to determine if the “auxiliary” transmitter power is above the TX Auto Level. If the auxiliary transmitter fails to turn on or if it does not produce more power than the original (main) transmitter, the SWP-300 will return to the original transmitter. Note: The SWP-300 will only execute the TX Auto Return function ONCE. This function ensures that the station remains on-air with the highest possible power given the state of the two connected transmitters.

Note: The SWP-300 will NOT attempt to auto switch if the SWP-300 has opened the air transmitter interlock due reflected power in excess of the reflected power level setting.

## **Automatic Antenna Switching: (2 – Switch SWP-300 models only)**

***This function requires an optional DPS-100D RF power sensor for forward and reflected power.***

When the SWP-300 Three-strike algorithm detects a reflected power level in excess of the user configured REF PWR LEVEL, the SWP-300 will execute the transmitter turn off sequence, and connect antenna B as the air antenna by moving SWITCH 2 to the B position. The SWP-300 will then execute the air transmitter turn on sequence.

### SIMPLIFIED SYSTEM INTERCONNECTION DIAGRAM SINGLE SWITCH CONFIGURATION

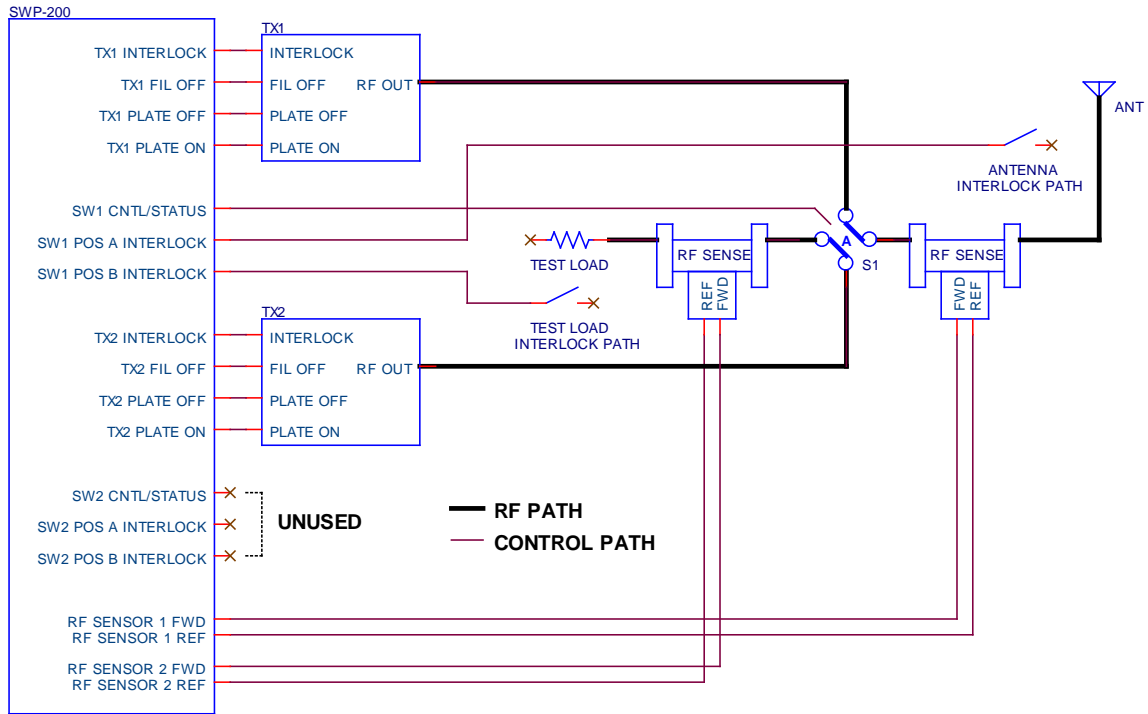

### SIMPLIFIED SYSTEM INTERCONNECTION DIAGRAM 2 - SWITCH CONFIGURATION

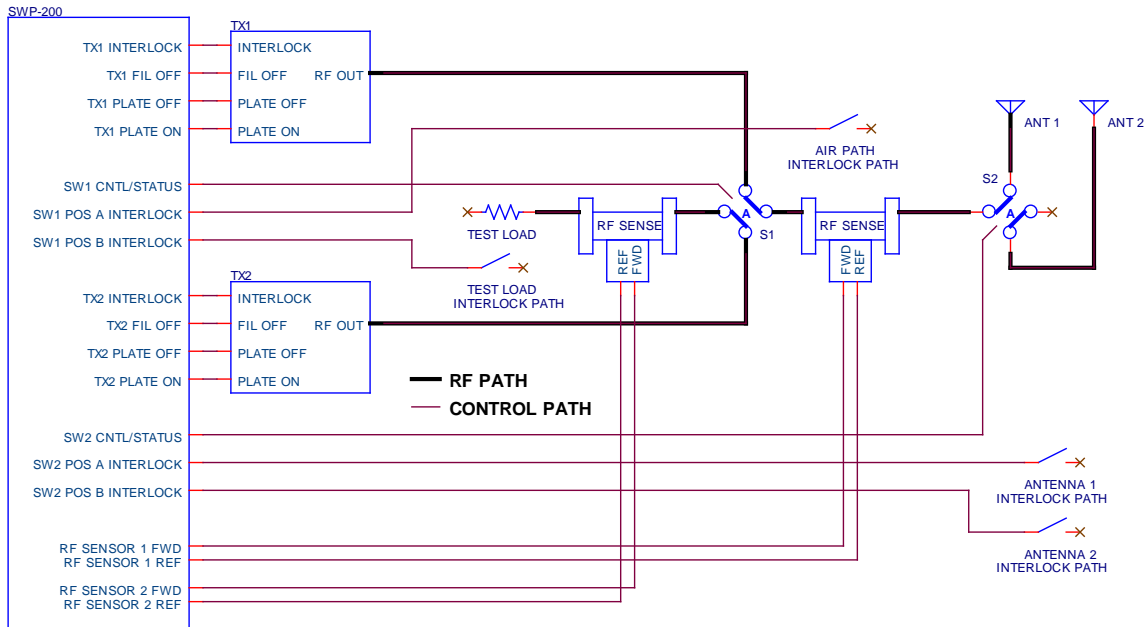

### ***Front Panel Operation:***

To select a transmitter to switch press the down arrow key to show the current transmitter switch status. Press the appropriate F1 or F2 key to select the alternate transmitter. For two switch models to select an antenna press the up key to show the current status of the antenna switch and then select the antenna by pressing the appropriate F1 or F2 key. The Red F3 button is TX 1+2 (BOTH) Off and the Green F4 button is TX selected to AIR On. F3 turns both transmitters off and defeats auto switching operation. F4 will turn on the transmitter selected to the air path. **Note:! When placing the SWP-300 in Auto Switch mode the F4 button must be depressed to initiate the Auto Switch function. – Also note that it is not possible to place the SWP-300 in Auto mode unless RF power above switch threshold is indicated in the air path.**

When depressing a mode all interlock relays are opened (de energized). TX OFF commands if used are issued next. Next the attached switch will move to the desired position. The interlock relays are then closed (Re energized). Last, the TX selected to the active load such as an antenna is commanded on if this connection is made.

Remote operation of the SWP-300 series functions identically to the front panel operation discussed above. Momentary closure to common of the appropriate pin on the remote connector or BDI Stack GUI command will cause the SWP-300 to operate as described above. BDI Stack remote control functions operate in identical fashion to front panel and GPIO remote control.

The SWP-300 normally displays data from the main (air) RF sensor. To view the auxiliary RF Sensor information press the left arrow key. To return to the main menu press the left arrow key again. After 5 minutes the SWP-300 will automatically return to the main screen.

The lower left corner of the main screen will display “M” when auto switching is disabled and “A” when auto switching is enabled. When one or more three strike counter events have been recorded, the lower left hand corner of the display will have 1 to 3 bell-shaped characters to indicate the number of strikes. After the 3<sup>rd</sup> strike, the air transmitter interlock will be latched in the open position until the three strike counter is reset from the front panel using the “X” key or by the remote reset input. The three strike counter can be cleared at any time by pressing the “X” key.

### ***Remote Operation:***

Remote commands are issued to the SWP-300 via J1,2 and 5 by connecting the command pin associated with that function to command common using a momentary contact. Status feedback is provided via an open collector driver

which is active low (sinking) when the associated function is enabled. Refer to page 6 TX CTL/Interlock Connection table for connection information.

For the purpose of connecting to a second remote control or for a local control status panel the following command inputs and status outputs are provided on the rear panel of the SWP-300 connector J1 SW1 LOCAL CONTROL/STATUS:

**TX 1(2) TO AIR** - Selects the transmitter which will be connected to the SW1 Position A (air) load. The associated status pin indicates which transmitter is selected to the air position.

**TX 1+2 OFF** – Turns OFF both transmitters by issuing plate / filament off commands. The associated status output indicates when both transmitters have been commanded OFF. Issuing this command will cause the SWP-300 to suspend automatic transfer if enabled.

**AIR TX ON** – This command will close both interlock paths and issue a plate on command to the transmitter which is selected to the AIR position. The associated status output will be active when the air transmitter is on.

**TX MANUAL** – This command suspends automatic transmitter switching by the SWP-300. When the SWP-300 is in the manual mode the associated status output will be active. In this mode switch operations will only occur with front panel or remote control actuation.

**TX AUTO** – This command will activate the SWP-300's automatic transmitter switching function. When automatic switching is enabled the TX AUTO status pin will be active. NOTE: The SWP-300 requires the user to issue an AIR TX ON command to turn on the transmitter if it is not already on. For safety reasons it WILL NOT automatically issue TX ON when placed in TX AUTO mode.

**TX 1(2) INTERLOCK STATUS** – These status pins will be active when the interlock path to the associated transmitter is closed. The status pin reflects the state of whichever interlock path is connected to each transmitter based on the position of the 4 port switch.

**REMOTE FAULT RESET** – This input resets the SWP-300 Three Strike Counter to re-enable transmitter interlocks after a reflected power fault. This input is only active after a "3<sup>rd</sup> Strike" and will not reset the three strike counter unless it has reached the 3<sup>rd</sup> strike. This allows the operator to view the 1<sup>st</sup> and 2<sup>nd</sup> strike indicators to be aware of a possible intermittent condition. The front panel fault reset is used to clear the counter prior to the 3<sup>rd</sup> strike.

**AC PWR LOSS INPUT** – This input may be connected through the normally closed contacts of a relay and the common contact to the SWP-300 common.

The external relay should be configured such that it is energized when power is applied to the transmitter. A loss of power will close the contacts to inhibit the SWP-300 from attempting to switch transmitters before backup power stabilizes or if AC power has been lost to both transmitters. This closure must be present for the duration of the AC power loss event. **DO NOT UNDER ANY CIRCUMSTANCES MAKE CONNECTION TO 120 VAC DIRECTLY!!**

See drawing on next page which illustrates how to configure this feature.

SWP-200 AC POWER LOSS DETECTION EXAMPLE

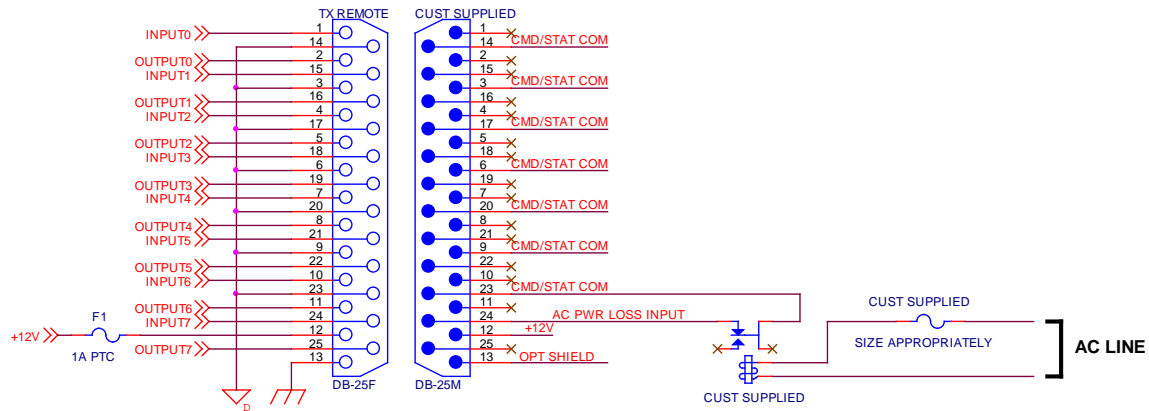

- NOTES:
1. RELAY COIL VOLTAGE MUST MATCH AC LINE VOLTAGE.
  2. FUSE SHOULD BE SIZED APPROPRIATELY FOR RELAY COIL CURRENT.
  3. OTHER REMOTE & STATUS CONNECTIONS HAVE BEEN OMITTED FOR CLARITY.

The above connector diagram is for illustration purposes. The actual connector that these connections are made to is rear panel J1 Remote Control.

For the purpose of connecting to a second remote control or for a local control/status panel the following remote commands and status outputs apply only to the SWP-300-2 switch model via J5 SW2 LOCAL CONTROL/STATUS:

**ANT MANUAL** – This command suspends the automatic antenna switching function of the SWP-300. The associated status pin will become active indicating that the SWP-300 is in MANUAL mode.

**ANT AUTO** – This command will activate the automatic antenna switching function of the SWP-300.

### Remote Control Descriptions for J3 Remote Antenna Switch Connector

**Air > Ant1 CMD** – Selects Antenna 1 (Main) for transmitter selected to “Air”

**Air > Ant2 CMD** – Selects Antenna 2 (Aux.) for transmitter selected to “Air”

**Ant Manual CMD** – Places SWP-300 in manual antenna select mode. No automatic operation of antenna selection

**Ant Auto CMD** – Places SWP-300 in Auto select of antenna if high reflected power is detected by DPS-100D power meter

## VI. Control Output Connection Information

### J3 Control 1-8 OUTPUT

Control 1-8 are dry relay outputs available on rear panel connector J3 Control 1-8 OUTPUT. NC/C/CN connections are available. See the diagram below for pin configuration information.

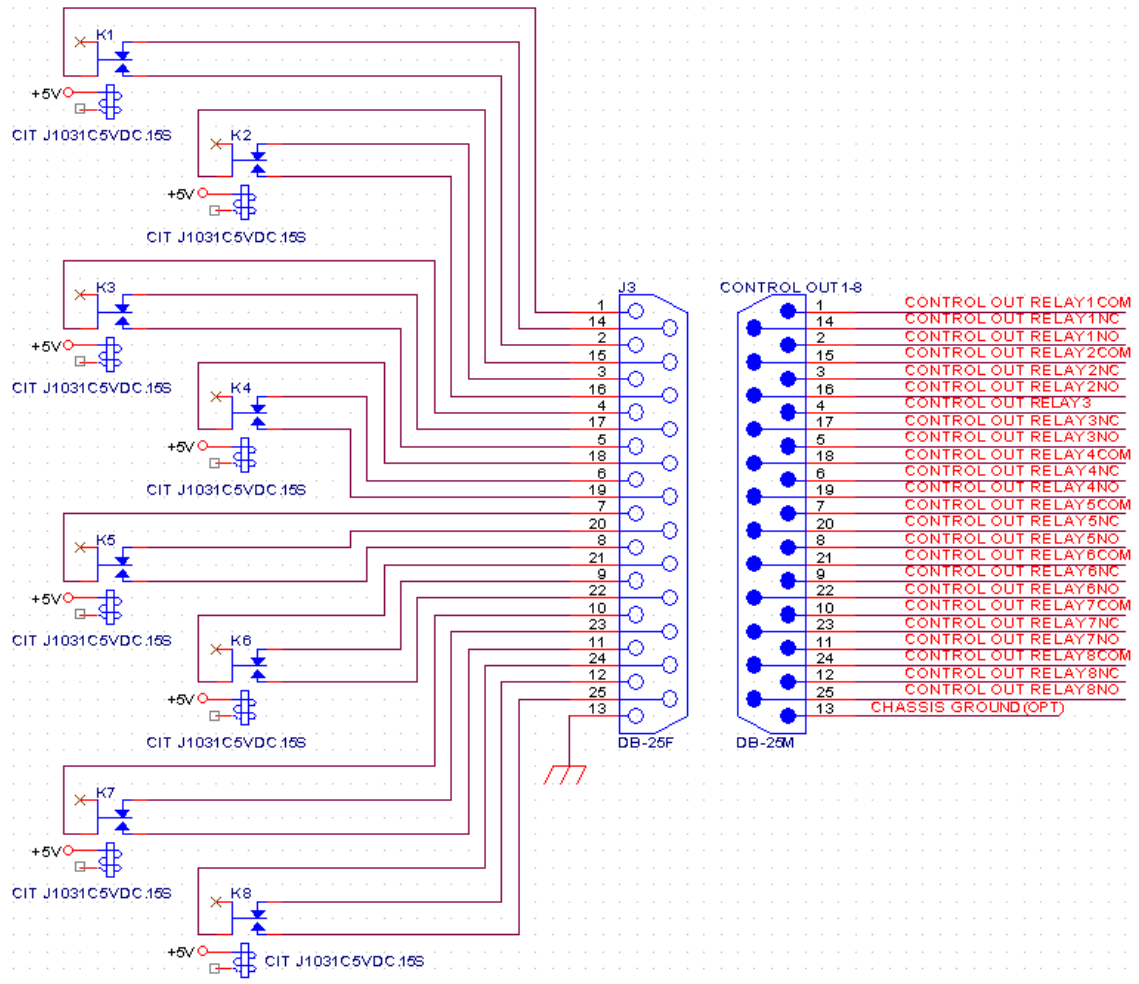



## VII. Status Inputs 1-8 Control Outputs 9-16

### J6 ST IN 1-8 CTL OUT 9-16

Control 9-16 are solid state control outputs are available via J6 ST IN 1-8 CTL OUT 9-16. See the diagram below for pin configuration information.

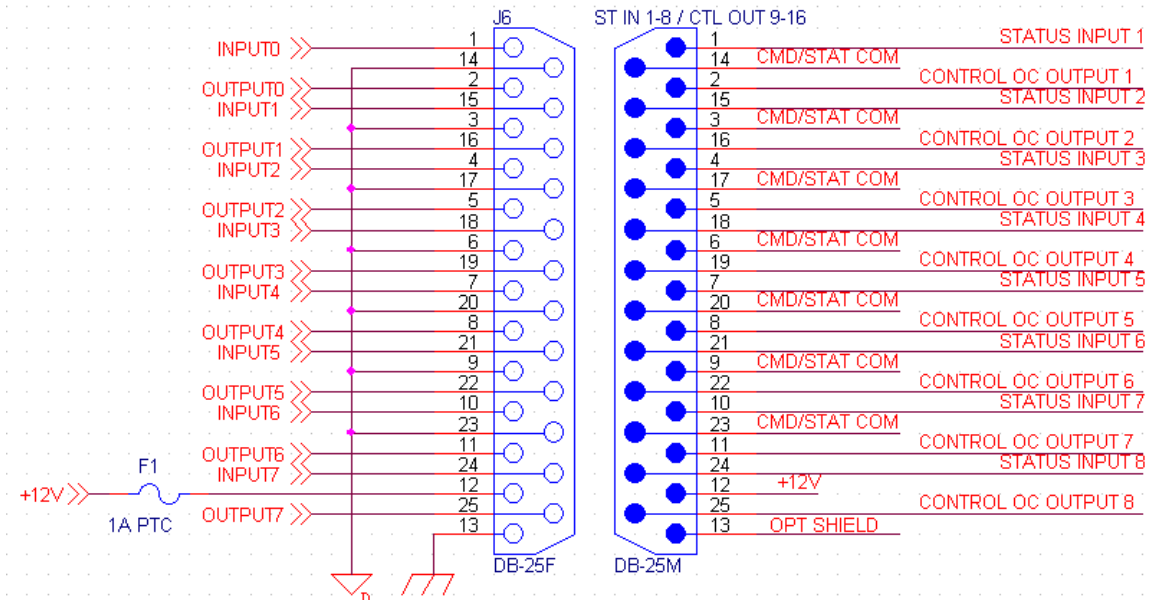

### STATUS INPUT Connection Information

Status inputs 1-8 are available on J6 ST IN 1-8 CTL OUT 9-16 connector on the rear panel. See the diagram above for pin configuration information. All status inputs to the SWP-300 should provide an active low to the SWP-300.

## VIII. J2 A/D IN/TX VSWR FLT. STATUS Connection Information

The SWP-300 can accept 4 analog inputs with ground reference to + 5 VDC. See the diagram below for analog input connection information along with TX VSWR Fault Status connection. In addition there is provision to provide status input for TX ½ from the transmitters connected for display on the BDI Stack GUI. Status connections should provide an active low to the SWP-300.

Analog inputs should be connected to Aux Analog in 1-4 and ground connection should be connected to input common as shown on the connector diagram.

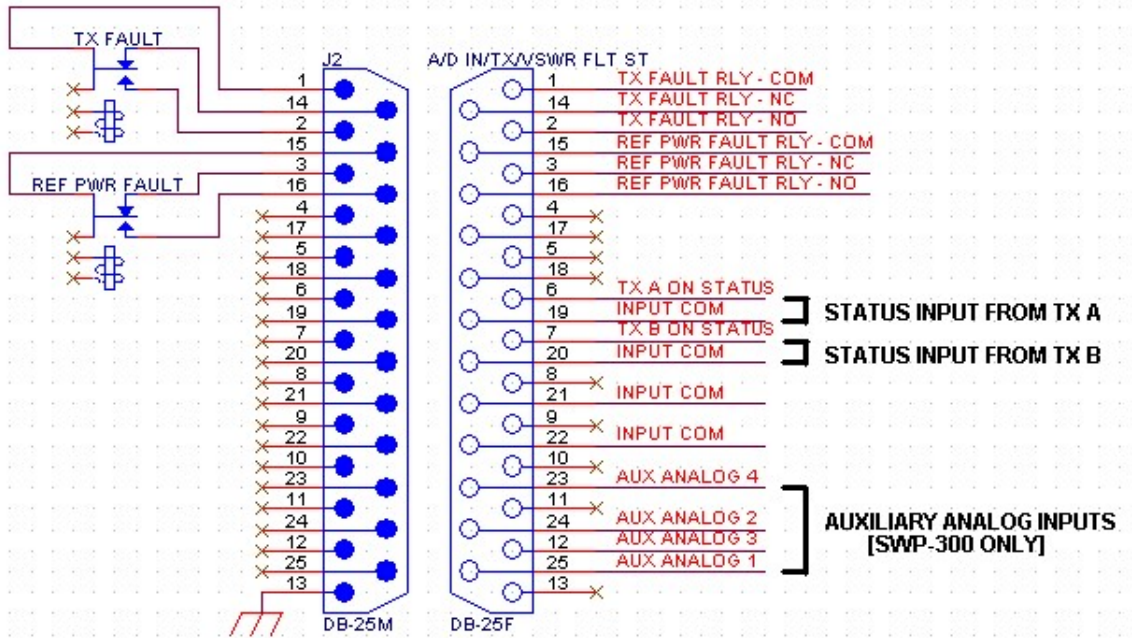

## IX. Communications Interface Information

To configure the SWP-300 for LAN operation, connect the LAN interface to a local router with category 5 local area network cable. Next, open a browser window and enter the default IP address for the SWP-300. **The factory default IP address is: 192.168.1.107**

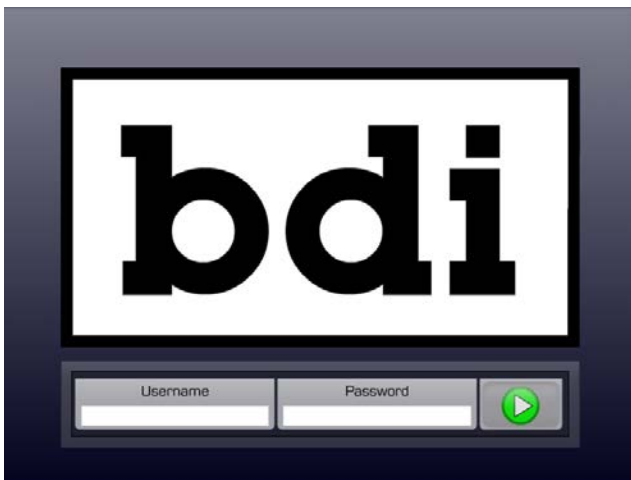

Default Username is: **username** – lower case

Default Password is: **password** – lower case

Press the right arrow key to enter the IP configuration screen:

Network Setup	IP Address 192.168.1.107	IP Mask 255.255.255.0
MAC ADDRESS 54:10:EC:51:BE:B2	Primary DNS Server 192.168.1.1	Gateway 192.168.1.1
Unit Name BDI New York	Username username	Password password
SNMP Port 161	Read Community public	Write Community private
FW REVISION SWP V2.3.28	LOAD	SAVE
BACK		

This screen allows the user to change the IP address, subnet mask and default gateway to match local LAN configuration. Contact your network administrator to obtain the correct settings. Click the [OK] Check Mark button after changes are made. **In order for the changes to take effect you must power cycle the SWP-300 unit. Failure to do this will result in the unit remaining on the default settings**

**NOTE: Be sure to record the new IP address before power cycling (see below). Failure to record the new settings may cause difficulties in locating the SWP-300.**

It is strongly recommended that you record the new IP parameters, username and password:

NEW IP ADDRESS: \_\_\_\_\_

SUBNET MASK: \_\_\_\_\_

PORT ASSIGNMENT: \_\_\_\_\_

NEW USERNAME: \_\_\_\_\_

NEW PASSWORD: \_\_\_\_\_

To allow remote access to the SWP-300 your router and firewall must be configured to allow requests to **PORT 161** to pass to the IP address configured for the SWP-300. Failure to do so will prevent access to the SWP-300 from outside the local network. Port 161 is the default port and can be changed but the new port must be forwarded as well.

At this point you can use the BDI Stack software to access the SWP-300 unit. Please refer to the BDI Stack Technical Reference Manual and software available for free download on our website. Go to [www.broadcast-devices.com](http://www.broadcast-devices.com) and navigate to our downloads page for access to the software and manuals.

### **Broadcast Devices, Inc. BDI Stack Graphical User Interface**

Broadcast Devices, Inc. now has a available for free download a graphical user interface that can be used to monitor and control the SWP-300 series motorized switch controller from a remote location with any Windows XP, 7, 8 and 10 operating system. The interface allows for a single page view of all parameters and control functions. The screen shot below shows the interface when installed and connected to an SWP-300. In this example the unit is displaying power, temperature, pressure and interlock status of a connected DPS-100D Power monitor. Note that there are also command features available including movement of the switch from position A to B and for TX On/Off command.

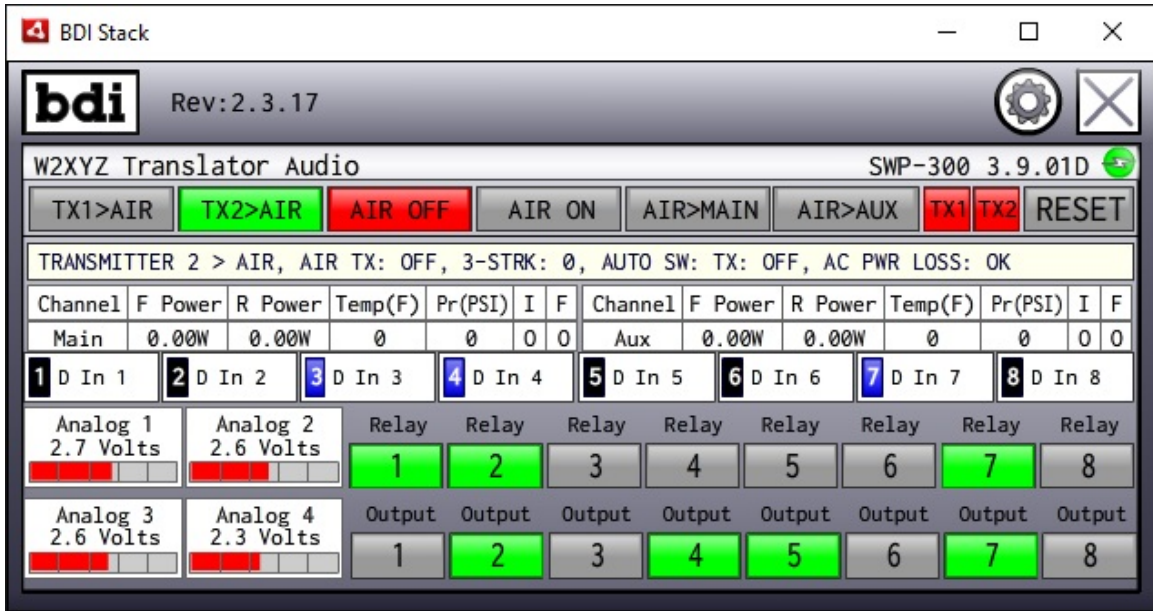

**BDI Stack SWP-300 Main Screen**

The BDI Stack graphical interface can be found at [www.broadcast-devices.com](http://www.broadcast-devices.com) Click on the downloads tab on the main page and you will find the BDI Stack Graphical User interface for Windows or Android operating systems software and technical reference manuals to aid in the installation and operation of the program,

## X. Specifications

### SWP-300-1/2

Power Indication:	Watts/Kilowatts accuracy within +/- 5% of reading – With DPS-100D installed
Control Input	Momentary contact to ground
Control Output to Switch Rating 24VDC @6 A.	Dry relay form C contact closure Contact
Status Output	Open collector output – Active Low
Status Inputs	8 Open Collector
Control Outputs	8 Relay NC/C/NO, 8 Open Collector Outputs
Connector Control in/Status out	DB-25 Female
Connector Type Control to	Switch DB-15 Female
Interlock/TX Control	DB-25 Female
RS-485	For use with DPS-100D DB-9 Female
LAN connection	RJ45 TCP/IP – SNMP v2 Agent
Physical Specification	19" L X 1.75" H X 10" D – Standard EIA rack
Electrical Requirements	100-240 VAC 50-60 Hertz
Environmental	0 – 60 degrees C. non condensing atmosphere

## VIII. Warranty

Broadcast Devices, Inc. products manufactured for Electronics Research, Inc. are warranted against failure due to faulty materials or workmanship for a period of two years from the date of shipment to the ultimate user. The warranty covers repair or replacement of defective parts at the factory, provided the unit has been returned prepaid by the user. All shipments to the factory shall have affixed to the outside of the container an R. A. number obtained from the factory. The above warranty is void if the unit has been modified by the user outside of any recommendations from the factory or if the unit has been abused or operated outside of its electrical or environmental specifications. If customer conducted field tests suggest that the unit may be faulty, whether or not the unit is in warranty, a full report of the difficulty should be sent to Broadcast Devices, Inc. factory at Cortlandt Manor, New York. The office may suggest further tests or authorize return for factory evaluation.

Units sent to the factory should be well packed in the original packing if possible and shipped to Broadcast Devices, Inc. Please go to [www.broadcast-devices.com](http://www.broadcast-devices.com) for shipping address. Remember to affix the R.A. number to the outside of the carton. Any packages received without such R.A. number will be refused. Note: freight collect shipments will also be refused. When the unit has been received, inspected and tested, the customer will receive a report of the findings along with a quotation for recommended repairs, which are found falling outside of the standard warranty. Units returned for in-warranty repairs which are found not to be defective will be subject to an evaluation and handling charge. In-warranty units will be repaired at no charge and returned via prepaid freight.

Out-of-warranty units needing repair require a purchase order and will be invoiced for parts, labor, and shipping charges.

When ordering replacement part, always specify A) Part number or Description, and Quantity; B) Date of Purchase, Where Purchased; C) Any Special Shipping Instructions. Always specify a street address, as shipping companies cannot deliver to a postal box.

Broadcast Devices, Inc. is not responsible for any other manufacturer's warranty on original equipment. Nor are we responsible for any failure, damage, or loss of property that may occur due to the installation or operation of our equipment outside of recommended specifications.

Broadcast Devices, Inc. may from time to time make changes to the materials used in the manufacture of its equipment and reserves the right to do so without further notice.

# XI. Typical Switch Connection Diagrams

## Electronics Research, Inc. Coaxial and Waveguide Motorized Switches

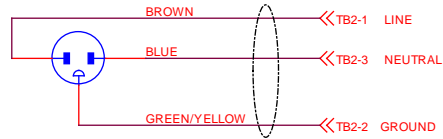
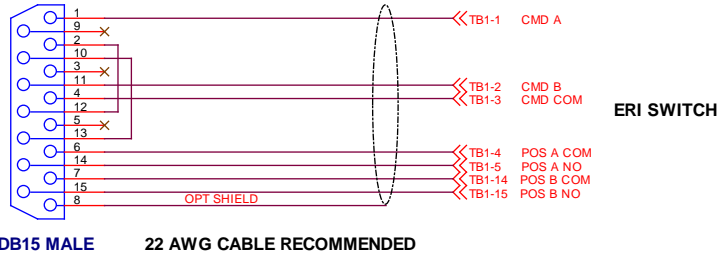
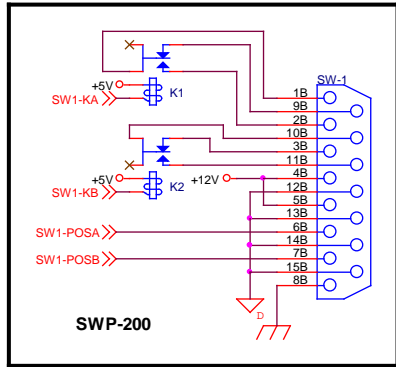

## Delta Electronics. Motorized Coaxial Switches

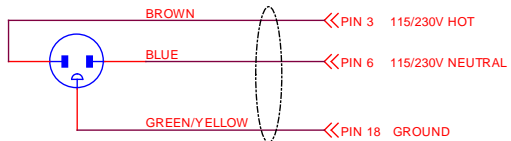
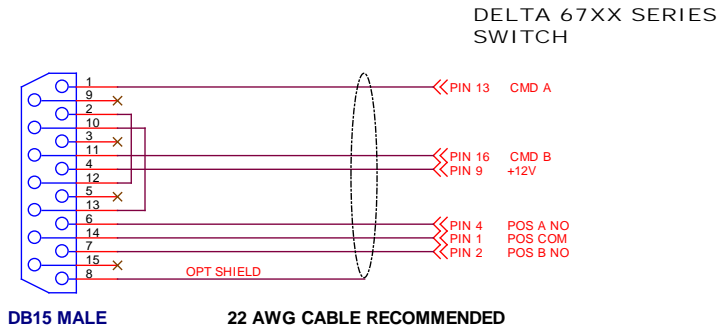
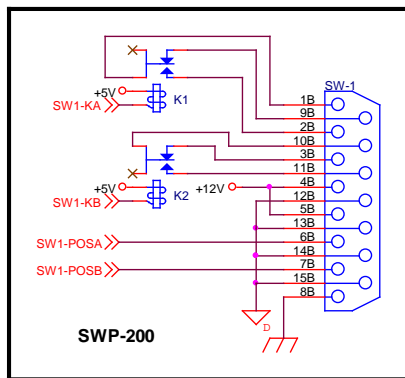

NOTE:  
SWITCH MUST HAVE DELTA D42-87-1 12V RELAY KIT INSTALLED.



# Dielectric/SPX 50000/60000 Series Coaxial Switches

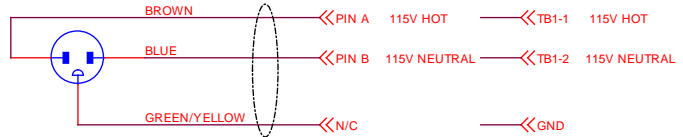
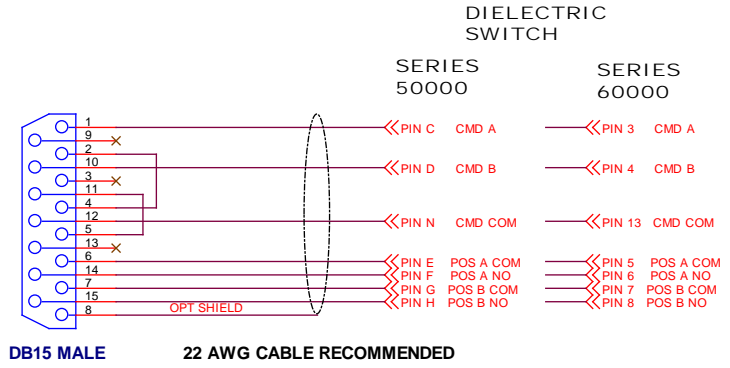
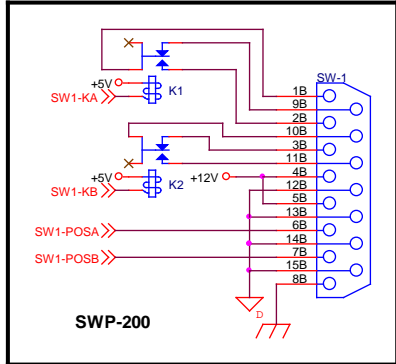

## MCI/Rymsa Coaxial Motorized Switches

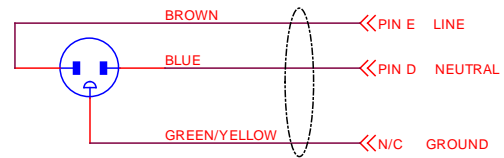
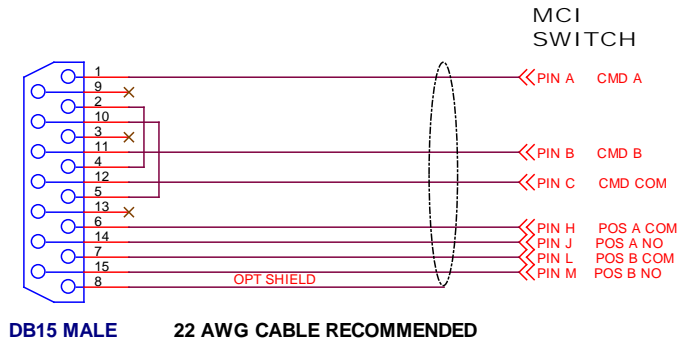
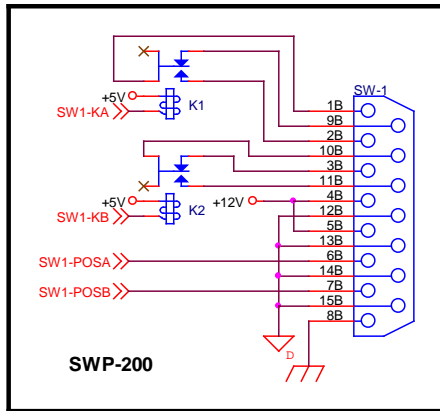

### NOTES:

1. CONNECTOR: MIL TYPE MS3102A2214P
2. SWITCH MUST HAVE K1 INSTALLED FOR 12VDC OPERATION.
3. K1 P/N: 7/8" & 3 1/8" SWITCHES: DS2E-ML2-DC12V - ALLIED 788-1057
4. K1 P/N: 4 1/16" & 6 1/8" SWITCHES: KUL11D15D-12 - ALLIED 886-0129

## MCI 61000 7/16 DIN/N Type Switch

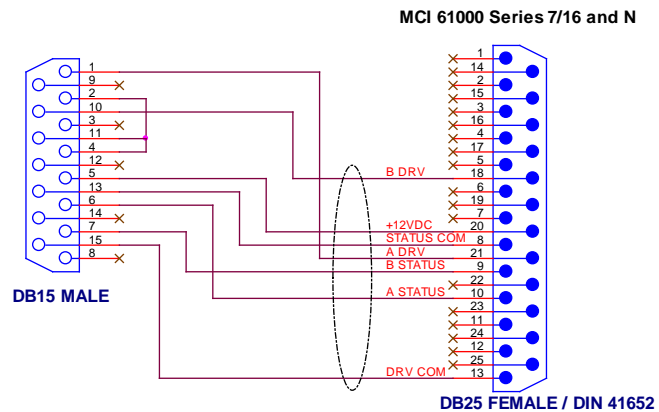
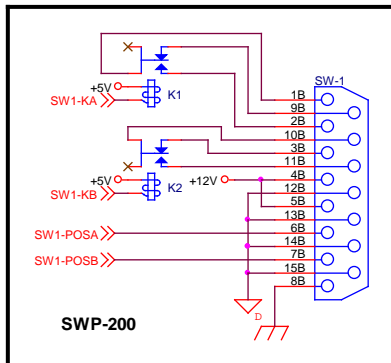

# Spinner Motorized Switch Series

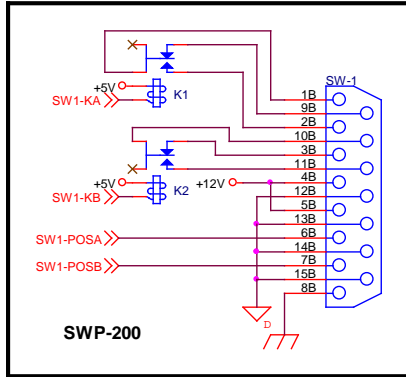

SWP-200

## SPINNER SOLENOID DRIVE

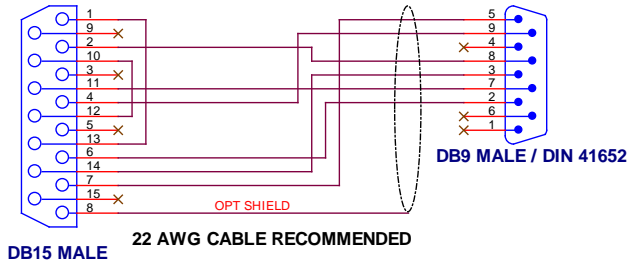

DB15 MALE

## SPINNER MOTOR DRIVE

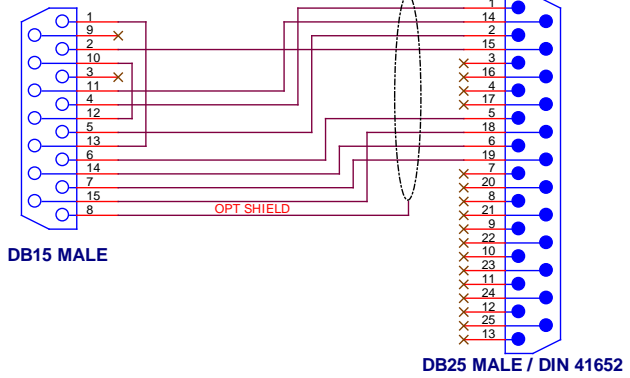

DB15 MALE

DB25 MALE / DIN 41652

## Myat 201-180-X Motorized Switch Series

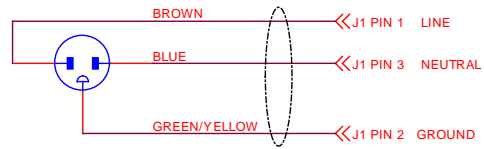
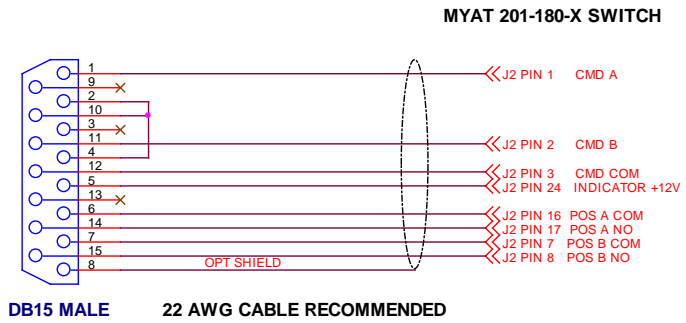
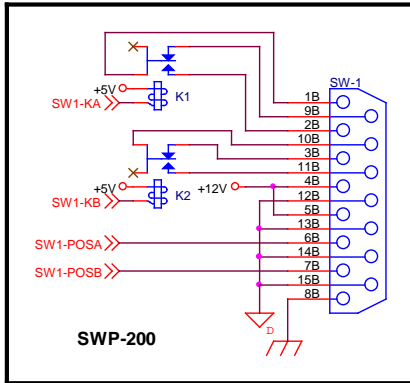

**NOTES:**

1. 24 PIN CONTROL CONNECTOR: MYAT P/N 180-135
2. SWITCH MUST HAVE K1 - MYAT P/N 175-40 INSTALLED FOR 12VDC OPERATION

## Dow Key Solenoid Type 412-420132, 412-480132, 412-430132 Switch Series

