

# The REM-100 8 Button Lighted Pushbutton Panel



The REM-100 8 Lighted Pushbutton Panel has two groups of four lighted pushbuttons. Housed in a standard EIA single 19 inch rack enclosure this generic panel can be used for just about any purpose where push button control and LED status is required. Each push button is a single pole single through momentary switch. Each switch has an accompanying LED indicator. Both sides of the switch contacts are available at the rear panel connector so that isolated connections can be made if desired. There is also a header on the PC board that allows the switches to be configured for closure to common for simplified wiring. The LED indicators are common to a power supply pin on one side and each is isolated with a dropping resistor on the other. Simply ground the desired LED terminal to light it. In addition to the panel there is a sturdy steel back bracket that houses two DB-25 connectors for interface to each 4 button grouping. The panel comes without labeling or overlay. If you require a custom overlay for your project please contact us and we would be happy to quote custom artwork.

## Technical Specifications:

Number of buttons	8 in two groups of 4 momentary lighted pushbuttons
LED Voltage	5 - 24 VDC
Connector	DB-25 Male

### Schematic of Button Group

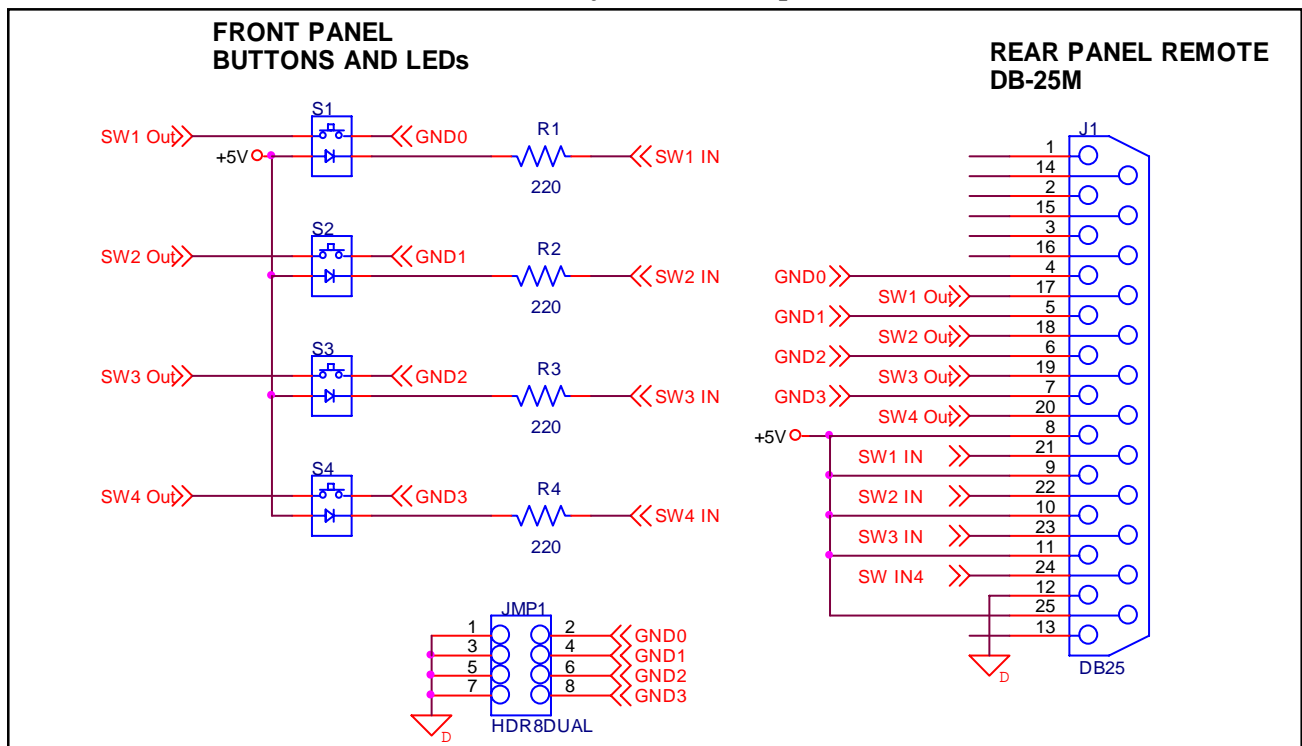

**Broadcast Devices, Inc.** 5 Crestview Avenue, Cortlandt Manor, NY 10567  
 Tel. (914) 737-5032 Fax.. (914) 736-6916  
 Visit us on the web at: [www.Broadcast-Devices.com](http://www.Broadcast-Devices.com)