



Broadcast Devices, Inc.

# ***CDS-302 Automatic Composite Switcher/Distribution Amplifier***

TECHNICAL REFERENCE MANUAL

**Broadcast Devices, Inc.  
5 Crestview Avenue  
Cortlandt Manor, NY 10567  
Tel. (914) 737-5032  
Fax. (914) 736-6916**

REV: C 01/04

## **Table of Contents**

### **The CDS-302 Automatic Composite Switcher/Distribution Amplifier**

#### **I. Introduction**

- A. Unpacking and Inspection**
- B. General Description**

#### **II. Specifications**

#### **III. Installation**

- A. Initial Configuration**
- B. Location and Hookup Considerations**
- C. Composite Connections and Adjustments**
- D. Composite Loop Through Connection**
- E. Remote Control/Status Connection**
- F. Automatic Operation**
- G. Manual Operation**

#### **IV. Warranty**

#### **V. Schematic Diagrams**

- A. Overall Schematic**

## Introduction

The CDS-302 Automatic Composite Switcher/Distribution System is intended to be used in conjunction with suitable FM or TV stereo generators and/or composite STLS, SCA and SAP generators for the purpose of switching between two composite sources and distributing these signals to main and back up exciters and provides a front panel test point. This is done with a high degree of isolation so that equipment can be interfaced easily. The typical configuration for the CDS-302 is to distribute a composite stereo signal to a main and back up exciter. The same can be done with virtually any signal applied to a modern broadcast exciter. The CDS-302 incorporates a loop through of the input signal so that the composite source selected can be routed to a suitable RDBS generator for pilot lock and RDBS injection. The CDS-302 has an integrated silence sensor that allows for the automatic switching of the incoming signal upon detection of user defined silence. The CDS-302 also has an auxiliary port for the addition of optional modules that can perform various conversions of the input signals. The following is a list of the modules available and their functions.

1. AES3C module, AES Digital Input to Stereo composite output. This module accepts an AES3 digital input and converts it to a stereo composite waveform which is then routed to the B input of the switcher
2. LRC module, Left/Right analog in to composite output. This module accepts a left and right analog signal and converts them into a composite stereo waveform which is routed to the B input of the switcher
3. CLR module, Left/Right Output stereo decoder. This module accepts the output of the A/B switcher and decodes the composite signal back to left and right. The output is available at the rear of the unit.

For pricing and availability of these modules, contact your local broadcast equipment dealer.

### A. Unpacking and Inspection

Carefully unpack the unit after receipt and inspect for damage that may have occurred during shipping. If damage is noted, contact the shipper immediately and file a damage claim. The contents of the package have been insured to cover total replacement cost. Make certain that the package contents are the same as noted on the packing slip. If not, contact Broadcast Devices, Inc. Check to make sure all mechanical parts are secure. Units are delivered from the factory configured for 120 volts A.C. 60 Hz. Operation. Check to make sure that the power source is correct for proper operation. Units are field configurable for 240 Volt operation. See initial configuration section of part III, installation section for different power configuration.

### B. General Description

A suitable composite stereo, S.C.A., R.B.D.S., or S.A.P. signal can be applied to the input connectors of the CDS-302. As supplied from the factory, the unit is configured to accept a balanced 10Kohm bridging input. If it is desired to unbalance or terminate the input see initial configuration under part III, installation instructions. All three rear panel outputs of the DA are configured to drive a 50-ohm cable.

Adjustments for individual output level can be accomplished from the front panel. Power indication is also provided on the front panel.

## II. Specifications

Input Impedance:	10K or 50 ohm balanced/unbalanced selectable
Output Impedance:	50 ohms unbalanced
Maximum Output level:	4 Volts Peak to Peak into 50 ohms
Gain:	6 dB variable
Frequency Response:	Better than +/- 0.05 dB from 20 Hz to 100 kHz
Total Harmonic Distortion:	Better than 0.05% into 50 ohms
Inter - Modulation Distortion:	Better than 0.05% S.M.P.T.E. 4:1
System Noise:	Better than 80 dB below 4 Volts Peak to Peak
Input Connectors:	2 - Isolated B.N.C.
Output Connector:	B.N.C. (2 rear, 1 front panel)
Power Requirements:	120/240 Volts A.C. 50 - 60 Hertz
Operating Temperature Range:	0 - 60° Celsius non condensing atmosphere
Physical Dimensions:	1.75 H X 19 W X 10 D (inches)

## III. Installation

### A. Initial Configuration

Before installing the unit it is a good idea to decide whether or not the unit will operate balanced or unbalanced and/or bridging or terminated at its input. Generally, to avoid ground loops between equipment it is advisable to operate the unit in the balanced configuration. If for some reason it is desired to operate the units unbalanced and/or to terminate the input to 50 ohms, locate the rear panel four position DIP switch. Push the switch section marked terminate down. If unbalanced inputs are desired, push the switch position marked unbalanced down. If the automatic feature is to be used, select 60 or 30 seconds silence by the following method, for 60 seconds push the 60 second switch down. For 30 seconds, place both the 60 and 30 second switches in the down position.

The unit as configured from the factory is set to accept 120 Volts A.C. 60 Hertz electrical power. To change the power setting, first remove the power cord from the power entry connector. Slide the plastic cover to the left and with a pair of long nosed pliers carefully remove the power select p.c. board from the power entry module. Select the desired power configuration by placing the power entry p.c. board back into the module so that the desired power setting can be read from left to right.

### B. Location and Hookup Considerations

Locate the CDS-302 in a 19-inch E.I.A. standard rack enclosure in close proximity to the equipment that it is going to interface between. Allow sufficient airflow space between equipment to allow for proper cooling. It is important that the cables being fed from composite sources such as stereo generators and STL receivers be kept as short as is practical. The CDS-302 can drive lines at least as long as 25 feet with no degradation of signals. It is advisable to keep all cable lengths as short as possible to prevent stray R.F. pick up.

### C. Composite Connections and Adjustments

Make all desired input and output connections to your external equipment. Make sure that the CDS-302 is plugged in to a properly grounded A.C. receptacle. If possible, interrupt the audio feeding the CDS-302 and measure the signal to noise ratio with a suitable voltmeter. If the noise measurement obtained is acceptable you can proceed to the final adjustment of the unit. If the noise is high there may be stray R.F. pick up or a ground loop. It is a good idea to listen to the

system with a suitable audio monitor to determine the source of the noise. Hum is a common noise present. If hum is present, start by removing one cable at a time to determine the source of the ground loop. If the hum disappears or changes level when a cable is disconnected, a loop exists between the CDS-300 and the equipment at the other end of the cable removed. This will generally not happen with an input unless the unit has been configured for unbalanced operation. If this is the case, try the balanced input mode of operation. If a ground loop is present between the CDS-300 and an exciter or STL, feed the CDS-300 to a balanced input. Most modern exciters accommodate balanced cables.

#### D. Composite Loop Through Connection

The CDS-302 can route the selected input to an external device such as an RDS generator or composite processor by connecting a suitable cable to the loop through out connection on the rear of the unit. The output of the external device can then be routed back to the DA portion of the CDS-302 by connecting it to the loop through input connector. Once these connections have been made, the loop through switch should be placed in the "in" position by sliding it to the left as viewed from the rear of the unit.

As shipped from the factory, the CDS-302 is adjusted to produce unity gain from input to output. It may be necessary to adjust levels as some exciters can require slightly different levels to produce 100% modulation. Simply adjust the front panel controls for suitable modulation on each exciter.

#### E. Remote Control/Status Connection

Refer to the table below for remote control and status connections. The CDS-302 requires a momentary ground closure for switching operation. The CDS-302 can accept an open collector output for this purpose or a simple relay closure will actuate a switching function. Status provided is a set of dry contacts offering NO/C/NC connection to remote control equipment.

##### Remote Control Status Table

Pin 1 Error Status Relay NO  
 Pin 2 Error Status Relay COM  
 Pin 3 Select B Input  
 Pin 4 Select A Input  
 Pin 5 Error Reset  
 Pin 6 Input Status Common  
 Pin 7 Input Status B NO  
 Pin 8 Input Status A NO  
 Pin 9 Ground

Momentary connection between pins 3,4 and Ground pin 9 activates switching function remotely. All status connections are dry contact.

#### F. Automatic Operation

For automatic operation it is necessary to first select whether the silence sensor will switch upon 30 or 60 seconds. For 60 second operation, place the rear panel DIP switch marked "60 sec" in the down position. For 30 second silence sensing, place both the 60 and 30 second switches in the down position. To operate the CDS-302 in the automatic mode first make certain that an adequate feed is input to the selected switcher input. The peak to peak signal should be on the order of 3.5 volts for proper operation of the silence sensor. Next, push the "auto" button on the front panel. Finally, push the error reset button to extinguish the error indicator LED. As long as a proper feed is present the switcher will not switch until silence is detected for more than the selected silence sense timeout. If silence is detected

and the silence sensor commands a switch, the error indicator LED will light and no further switching will occur until the error is reset from the front panel or via remote control. Once the error is reset, the unit will be ready to switch automatically as long as the “auto” button indicator LED is illuminated. It is still possible to manually switch the switcher from the front panel or by remote control if the unit is in the auto mode. It may be necessary to reset the error indicator after a manual switch in order for the unit to detect silence and automatically switch.

#### G. Manual Operation

To operate the CDS-302 in manual, simply depress the “manual” button on the front panel. The unit will function as a manual switcher taking commands from the front panel switcher buttons or from the remote control connector.

#### **IV. Warranty**

Broadcast Devices, Inc. products are warranted against failure due to faulty materials or workmanship for a period of one year from the date of shipment to the ultimate user. The warranty covers repair or replacement of defective parts at the factory, provided the unit has been returned prepaid by the user. All shipments to the factory shall have affixed to the outside of the container an R. A. number obtained from the factory. The above warranty is void if the unit has been modified by the user outside of any recommendations from the factory or if the unit has been abused or operated outside of its electrical or environmental specifications. If customer conducted field tests suggest that the unit may be faulty, whether or not the unit is in warranty, a full report of the difficulty should be sent to Broadcast Devices, Inc. factory at Cortlandt Manor, New York. The office may suggest further tests or authorize return for factory evaluation.

Units sent to the factory should be well packed and shipped to Broadcast Devices, Inc. 5 Crestview Avenue, Cortlandt Manor, NY 10567. Remember to affix the R.A. number to the outside of the carton. Any packages received without such R.A. number will be refused. Note: freight collect shipments will also be refused. When the unit has been received, inspected and tested, the customer will receive a report of the findings along with a quotation for recommended repairs, which are found falling outside of the standard warranty. Units returned for in-warranty repairs which are found not to be defective will be subject to an evaluation and handling charge. In-warranty units will be repaired at no charge and returned via prepaid freight.

Out-of-warranty units needing repair require a purchase order and will be invoiced for parts, labor, and shipping charges.

When ordering replacement part, always specify A) Part number or Description, and Quantity; B) Date of Purchase, Where Purchased; C) Any Special Shipping Instructions. Always specify a street address, as shipping companies cannot deliver to a postal box.

Broadcast Devices, Inc. is not responsible for any other manufacturer's warranty on original equipment. Nor are we responsible for any failure, damage, or loss of property that may occur due to the installation or operation of our equipment outside of recommended specifications.

## V. Schematic Diagrams

### A. Schematic Diagram



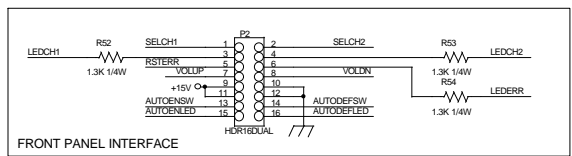
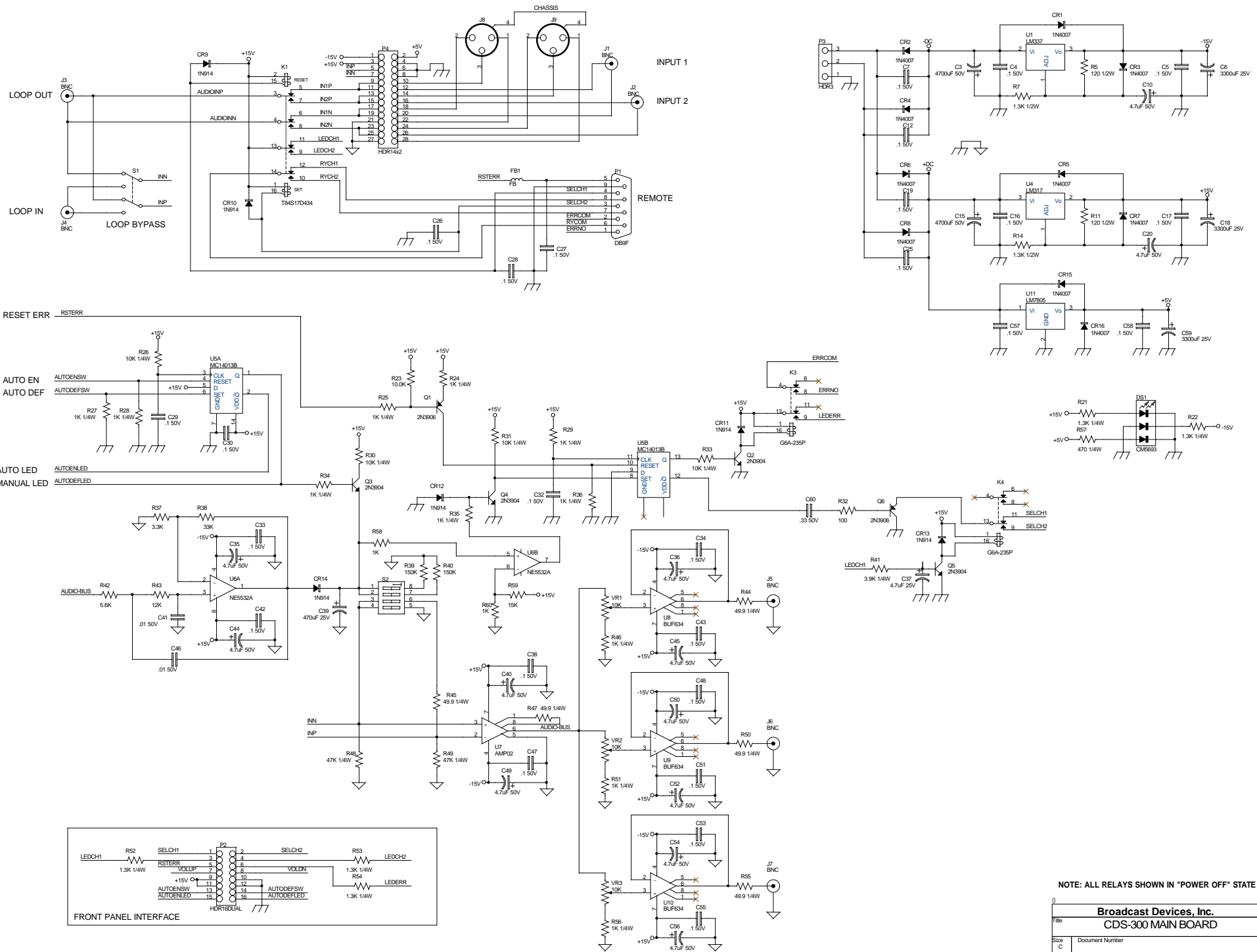

NOTE: ALL RELAYS SHOWN IN "POWER OFF" STATE

<b>Broadcast Devices, Inc.</b>		
<b>CDS-300 MAIN BOARD</b>		
File	Document Number	Rev
Size		<b>B</b>
C		
Date:	Sunday, March 07, 2004	Sheet 1 of 1