

AES-302 Internal Block Diagram

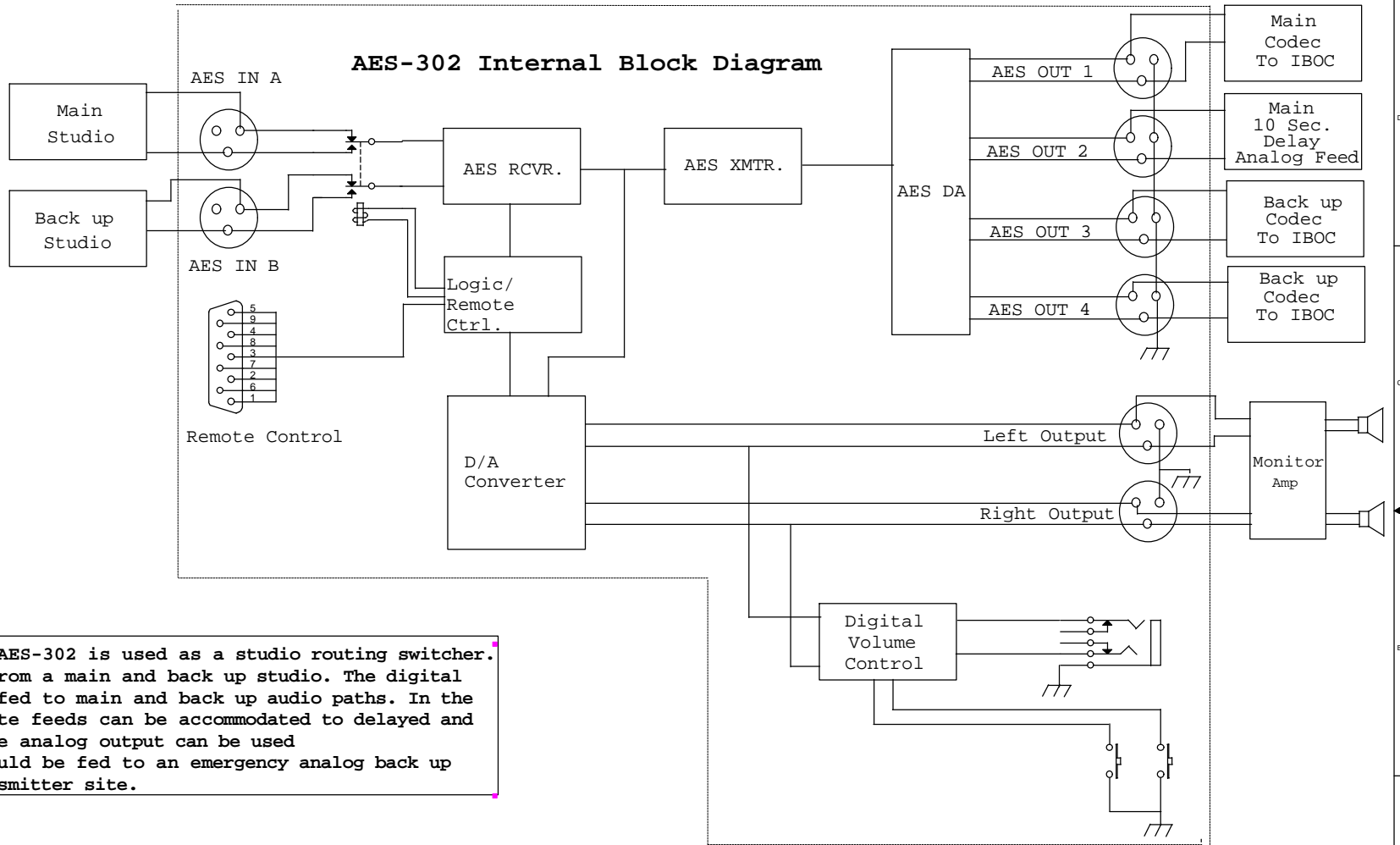

In this example the AES-302 is used as a studio routing switcher. The inputs are fed from a main and back up studio. The digital outputs can then be fed to main and back up audio paths. In the case of IBOC, separate feeds can be accommodated to delayed and non delayed paths. The analog output can be used for monitoring or could be fed to an emergency analog back up tie line to the transmitter site.



BDI Tech Talk Application Note

AES-302 Application 2 Studio Audio Source Selector

Call BDI Applications Engineering at (914) 737-5032
or email us at TechSupport@Broadcast-Devices.com