



Broadcast Devices, Inc.

Technical Reference Manual

AES-302N Digital Audio System

*Two Input Digital Audio Switcher
Four Output Digital Distribution System
96 KHz – 24 Bit Digital to Analog Converter*

Without Silence Sensor Version

**Broadcast Devices, Inc.
5 Crestview Avenue
Cortlandt Manor, NY 10567**

**Tel. (914) 737-5032
Fax. (914) 736-6916
World Wide Web: www.Broadcast-Devices.com**

Rev A. 08/04

Table of Contents

I. Introduction	3	
II. Unpacking	3	
III. Installation and Connections	3	
IV. Features and Operation	3	
V. Initial Operations Setup		4
Theory of Operation – Digital Switcher	5	
Error Switching Table 1.	5	
Remote Control Pin Out Table 3.	6	
VI. Specifications	7	
VII. Warranty	8	
VIII. Schematic Diagrams	9-12	

I. Introduction

The AES-302 Digital Audio System comprises of a two input AES compatible switcher, four output digital audio DA and digital to analog converter. The unit also has status and diagnostic error indicators for troubleshooting. The AES-302 is intended for use at unattended transmitter sites or for virtually any digital switching, distribution and/or D/A conversion application. The unit has the capability to automatically switch inputs upon detection of loss of clock and digital error flags. In addition to these features, the unit can function as an interface standards converter. As shipped from the factory the unit is supplied with XLR balanced connectors. The unit can be configured with any combination of input/output connectors if desired. Default factory supplied connections are XLR. Optical and S.P.D.I.F – RCA connections are available as options.

II. Unpacking and Inspection

Carefully inspect the unit after unpacking and make certain that no damage has occurred during shipping. If damage is noted, contact the shipper immediately and file a claim for damages. Each unit is carefully packed and carries full insurance against damage. Inspect the packing list and make sure that the contents of the package match those described on the packing list.

III. Installation and Connections

Select a space in suitable E.I.A. standard rack to locate the unit. Determine the local electrical power supply voltage and select the proper input voltage at the rear of the unit. As supplied from the factory, your AES-302 is setup for 120 V.A.C. 60 Hz unless noted otherwise. To change the input voltage to 240 volts, simply slide the plastic cover and remove the p.c. board in the E.M.I. protected power entry module and flip it so that “240 Volts” is legible from the rear as the board is placed back into the power entry module. No replacement of the fuse is necessary as the fuse supplied is rated for up to 250 V.A.C. operation. The unit is rated to run from 120/240 V.A.C. at 50 to 60 Hz operation. Make connections to the unit following good engineering practice. Supply power to the unit utilizing a three pronged grounded outlet. Do not lift the electrical ground to the unit at the power receptacle as this will result in a safety hazard. In the event of ground loops, lift the ground at the offending connection only. Make certain that the unit is afforded proper ventilation in the area of the top cover vent.

A. Digital Interface

Unless ordered as an option Inputs to the switcher are balanced XLR connectors conforming to the AES standard. The unit may be ordered with SPDIF or optical interface. Each XLR connection is terminated at 110 ohms as per the standard. SPDIF inputs are terminated at 75 Ohms. The balanced digital outputs are also XLR connections, which provide 110-ohm transformer coupled source impedance as per the standard. Again as an option outputs can be configured for SPDIF or optical interface.

B. Analog Interface

There is provided on the rear of the unit a left/right balanced analog output. This output is suitable for driving 600-ohm balanced lines and is short circuit protected. A headphone jack and volume control buttons are provided on the front panel of the unit for confidence monitoring of the incoming feed.

IV. Features and Operation

The AES-302 Digital Audio System is designed to select one of two AES3 compatible feeds and route it to up to four balanced, optical or unbalanced digital loads. It also contains a high quality digital to analog

converter providing a balanced left and right output. The unit features a front panel headphone output and volume control for easy confidence monitoring. The AES-302 can be used as a totally automatic switcher sensing loss of clock or any error displayed on the front panel to command the switcher to select the alternate feed. All automatic switching functions are user defined and can be initialized with a simple DIP switch setting upon installation of the unit. Command of the switcher can also be performed manually at the front panel or remotely.

Remote control of the unit is accessed through the rear panel 9 pin D connector. Simple momentary ground closure to the appropriate pin selects channels and error reset. Status of channel selected and error flag is also available at this connector. Refer to the pin out table 3 on page 6 for connection information. The interface is compatible with open collector command. The AES-302 supplies +15 V.D.C. for powering open collector actuators.

V. Initial Operating Set up

Attach input and output connections to the unit using the appropriate connector. The unit can be supplied with XLR, S.P.D.I.F., or optical connectors at any of the inputs or outputs. If the connector scheme supplied is not the one desired, consult the factory for a field or factory connector modification.

Plug the remote control plug in and tighten the connector screws in place.

You may select any or all of the error flag switching, which will command the switcher to switch to the alternate path. The “no lock” position S6-2 is always selected for automatic operation. Other error flags are selected by placing the designated DIP switches to the on position. Refer to the theory of operation section table 1 on page 5 for possible settings. Once this is done, the unit is ready to be powered up for operation. The default setting is to command the switcher upon loss of clock.

Once power is applied and a valid AES bit stream is applied to the selected input, the unit will default to “Manual” mode of operation. The LED indicator over the “Manual” button should be illuminated. In addition, the channel selected LED indicator will be lit. There should also be an indication of sample frequency. Press the error-reset button to clear any errors that might be indicated. If the digital audio stream feeding the active channel of the unit is valid and no errors occur the unit is ready for to be placed in the automatic mode if desired. If any of these errors occur after depressing the error-reset button, then the feed to the unit is defective and should be investigated. If all is in order, the unit is now ready for operation. All that is left to do is to select the desired feed and then if desired, place the unit in automatic switch mode by depressing the “Auto” button. The LED indicator will light indicating automatic control of the switcher. The unit will remain in this mode until an error is detected, loss of lock occurs, or the alternate feed is manually selected. If any of these events occur, the unit will switch to the alternate path and remain there until the error reset is performed from the front panel or remotely. **Please note that the Auto light will remain lit after an automatic switch but that the unit will perform no further switching until the error reset is performed.** This feature insures that the unit will switch only once after error or loss of clock is detected and prevents the unit from “hunting” back and forth. In addition, errors and lock loss indications are held in a buffer until cleared by the error-reset button. This is provided for troubleshooting purposes. If power is lost to the unit, the AES-302 will reset to “Manual” operation upon reapplication of power and remain in the channel last selected before power loss.

Theory of Operation – Automatic Switcher Circuit.

The AES-302 is designed to operate in automatic and manual switching modes. Upon application of power the unit defaults to the manual mode. In this mode switching between channels can only be accomplished by pressing the desired channel button or commanding the desired remote control pin. With power application C37 pulls the clock pin 3 of U6A low thus placing the IC in the reset mode whereby pin 1 Q output is pulled low. This in turn cuts off Q2 preventing automatic switching from occurring. Depressing the “Auto” front panel button places the unit in automatic operation. The actuation of the “Auto ” button

places a high on pin 6 of U6A which in turn sets Q output high enabling Q2. When an error or silence sense timeout occurs, the base of Q4 is pulled low which saturates Q3 momentarily. Momentary operation of Q3 is due to C45 being in an initially discharged state. When Q3 is turned on C45 begins to charge enabling Q3 to pass current. This same current passes through Q2 whose collector is routed to the proper coil of K1, which is the signal routing relay. K1 fires and switches to the alternate path. No further switching will occur because the error signal is still present on the base of Q4. This error signal will remain until the error-reset button is pressed. Once this occurs, Q4 is saturated by a 5 VDC signal from the error bus. Once Q4 saturates Q3 is cutoff and C45 begins to discharge through R32. CR19 prevents unintentional operation of the automatic switch circuit when errors are reset by momentarily cutting off Q2. C38 aids in preventing unintentional operation by holding the base of Q2 low until the error has had sufficient time to clear.

Any or all of the errors that appear on the front panel display can be made to actuate a switching operation. Factory default is all error and silence sensing selected. To change this configuration, remove the top cover and locate S6 on the motherboard. Refer to table 1 below for switch settings:

Error Switch Actuation Table 1

S6-1	Coding
S6-2	Unlock (must be selected for auto operation)
S6-3	Parity
S6-4	CRC
S6-5	Slipped Sample
S6-6	
S6-7	
S6-8	

S

Remote Control Pin out Table 3

Pin 1	+15 VDC @100mA.
Pin 2	No Connection
Pin 3	Select B Input
Pin 4	Select A Input
Pin 5	No Connection
Pin 6	Status Relay Common
Pin 7	Status – “B” Selected
Pin 8	Status - “A” Selected
Pin 9	Ground

Command input pins 3, 4, require a momentary closure to ground. Status connections are to dry contacts. Use no more than 24 VDC on these contacts or damage to the relay can occur.

VI. Specifications

Digital Inputs:	Two – Any combination of XLR, SPDIF or Optical
Digital Outputs:	Four – Any combination of XLR, SPDIF or Optical
Analog Output:	Balanced L/R XLR + 4 dBm 600 Ohms – Rear Panel Headphone out 600 Ohm unbalanced - Front Panel
Sample Rate Range:	8 – 96 KHz, Auto Detect and Lock
D/A Converter Resolution:	up to 24 bits
Remote Control:	Momentary ground closure selects channels and resets auto mode operation
Remote Status:	Channel Select Dry Contact NO/C/NC
Front Panel Controls:	7 - Momentary Push buttons - Switcher Selection, Error Reset, Auto/Manual Mode Operation Select, and Volume Up/Down
Front Panel Indicators:	Sample Rate, Lock Loss, Error Flags, Power Supply Status, Channel Status, Auto/Manual Mode
Power Requirements:	120/240 V.A.C. @ 0.25A; 50 – 60 Hz.
Operating Environment:	0 – 60 Degrees Celsius Non Condensing Atmosphere
Physical:	19"W X 8"D X 1.75"H Mounted via Standard E.I.A. 19" rack one rack unit occupied. Weight: 9 LBS.

VII. Warranty

Broadcast Devices, Inc. products are warranted against failure due to faulty materials or workmanship for a period of one year from the date of shipment to the ultimate user. The warranty covers repair or replacement of defective parts at the factory, provided the unit has been returned prepaid by the user. All shipments to the factory shall have affixed to the outside of the container an R. A. number obtained from the factory. The above warranty is void if the unit has been modified by the user outside of any recommendations from the factory or if the unit has been abused or operated outside of its electrical or environmental specifications. If customer conducted field tests suggest that the unit may be faulty, whether or not the unit is in warranty, a full report of the difficulty should be sent to Broadcast Devices, Inc. factory at Cortlandt Manor, New York. The office may suggest further tests or authorize return for factory evaluation.

Units sent to the factory should be well packed in the original packing if possible and shipped to Broadcast Devices, Inc. 5 Crestview Avenue, Cortlandt Manor, NY 10567. Remember to affix the R.A. number to the outside of the carton. Any packages received without such R.A. number will be refused. Note: freight collect shipments will also be refused. When the unit has been received, inspected and tested, the customer will receive a report of the findings along with a quotation for recommended repairs, which are found falling outside of the standard warranty. Units returned for in-warranty repairs which are found not to be defective will be subject to an evaluation and handling charge. In-warranty units will be repaired at no charge and returned via prepaid freight.

Out-of-warranty units needing repair require a purchase order and will be invoiced for parts, labor, and shipping charges.

When ordering replacement part, always specify A) Part number or Description, and Quantity; B) Date of Purchase, Where Purchased; C) Any Special Shipping Instructions. Always specify a street address, as shipping companies cannot deliver to a postal box.

Broadcast Devices, Inc. is not responsible for any other manufacturer's warranty on original equipment. Nor are we responsible for any failure, damage, or loss of property that may occur due to the installation or operation of our equipment outside of recommended specifications.

Broadcast Devices, Inc. may from time to time make changes to the materials used in the manufacture of its equipment and reserves the right to do so without further notice.

VIII. Schematic Diagrams

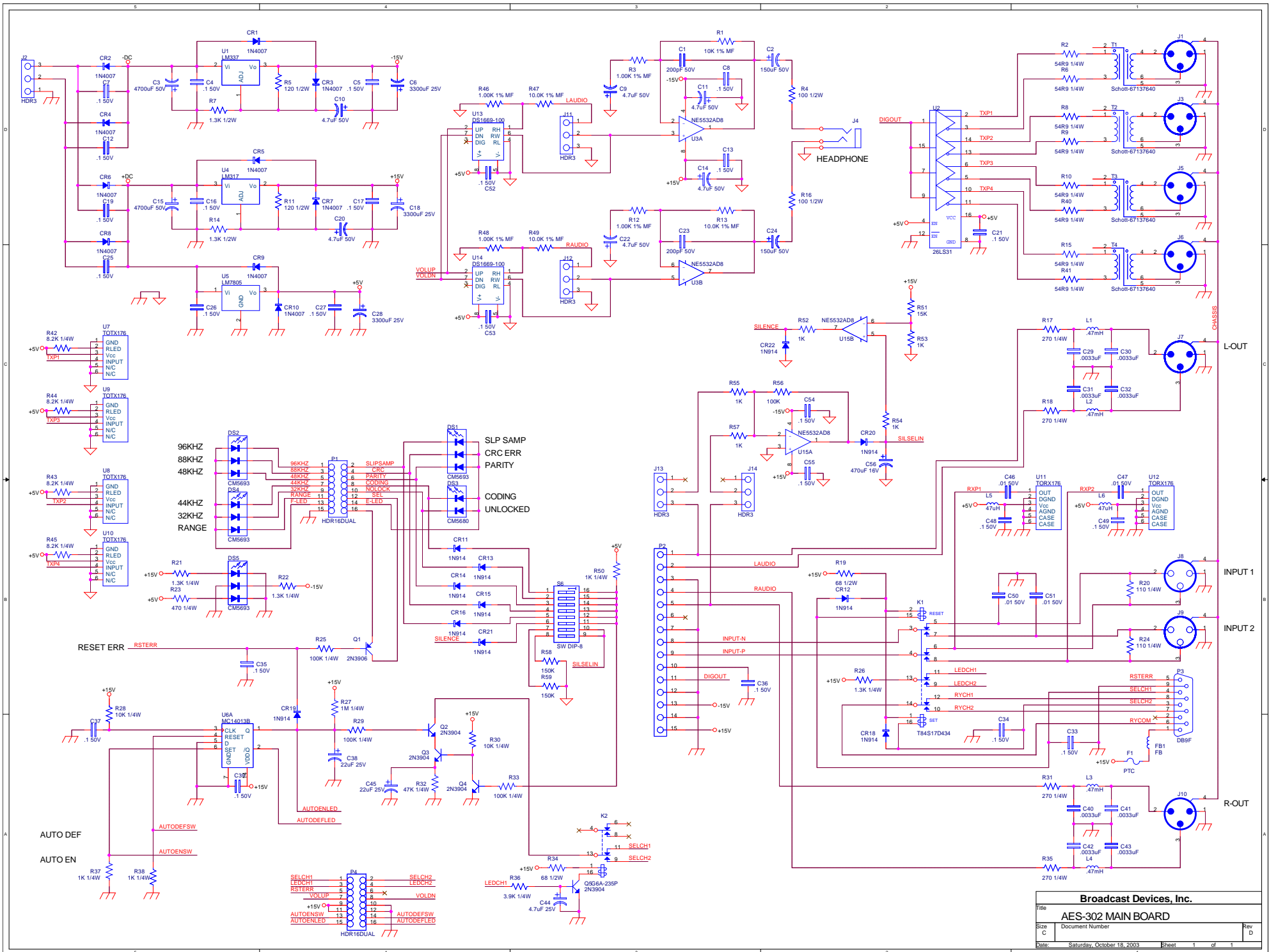

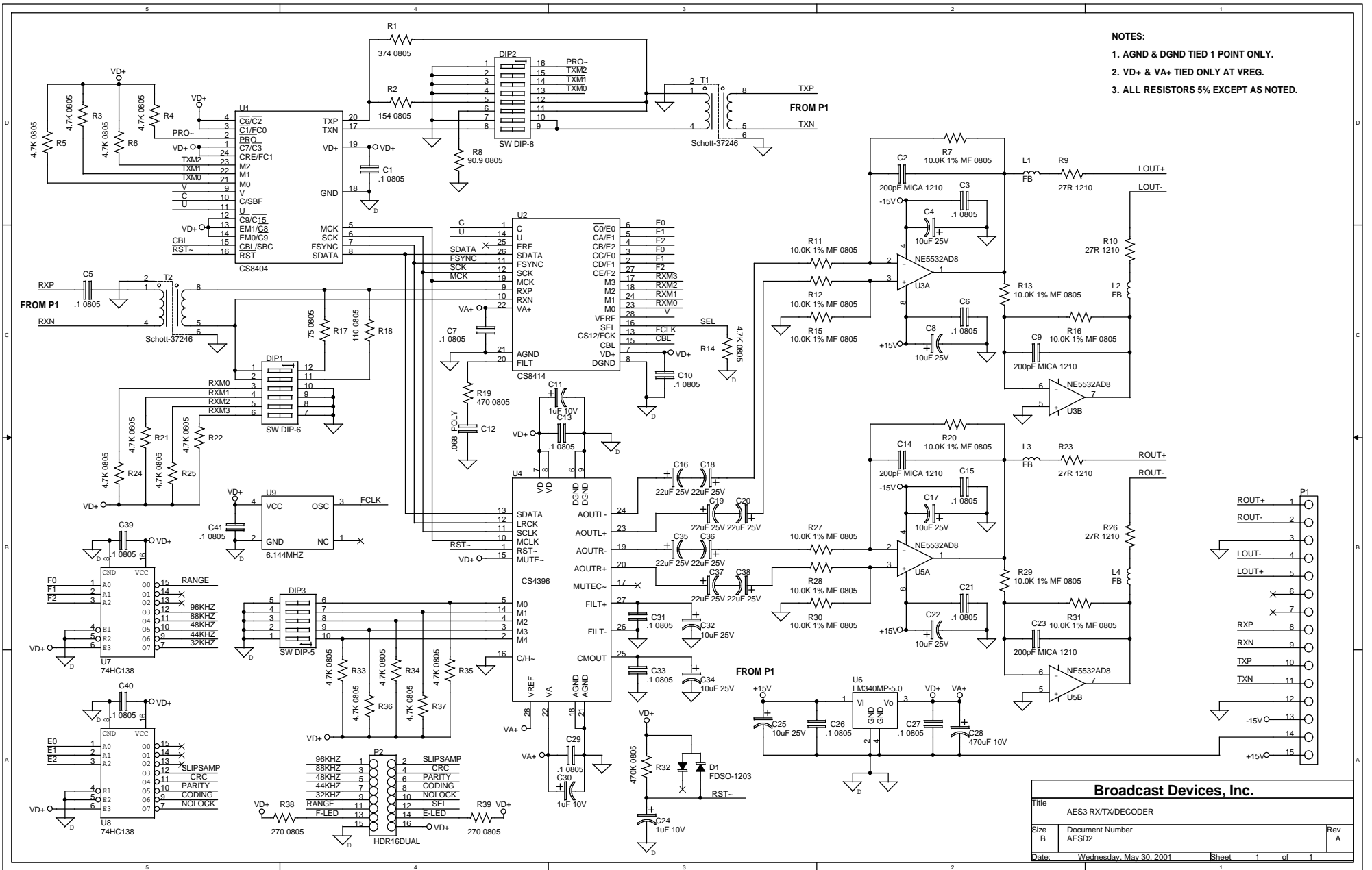

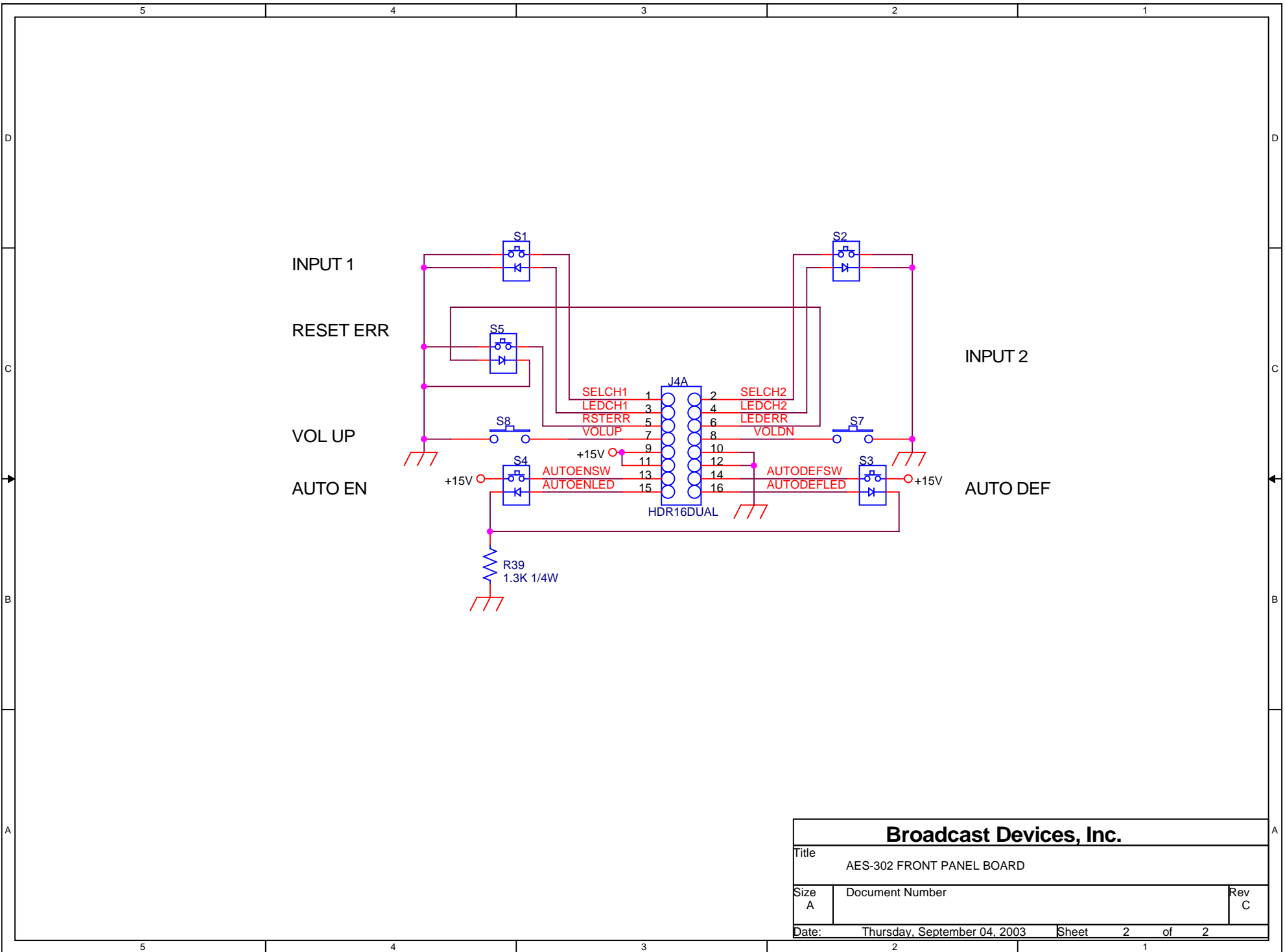

Broadcast Devices, Inc.

Title		
AES-302 FRONT PANEL BOARD		
Size	Document Number	Rev
A		C
Date: Thursday, September 04, 2003		Sheet 2 of 2