

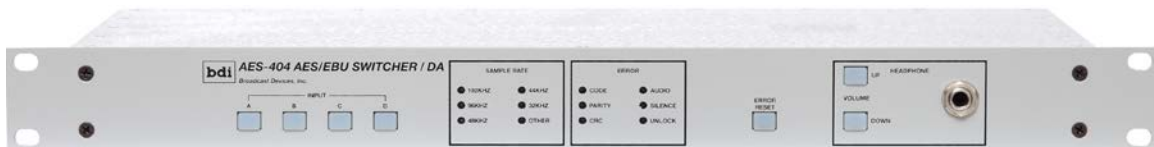

Broadcast Devices, Inc.

AES-404 Digital Audio Switcher/DA/Digital to Analog Converter

Technical Reference Manual



Broadcast Devices, Inc.

**Tel. (914) 737-5032
Fax. (914) 736-6916**

World Wide Web: www.Broadcast-Devices.com

Rev A. 12/14

Table of Contents

Introduction	3
I. Unpacking	3
II. Installation and Connections	3
III. Features and Operation	4
IV. Initial Operating Setup	4-5
AES-404 Optional Programming Functions	5-6
Remote Control Connections	6
V. Specifications	7
VI. Warranty	8

Introduction and Description

The AES-404 Digital Audio System comprises of a four input AES compatible switcher, two output digital audio DA and digital to analog converter. The unit also has status and diagnostic error indicators for troubleshooting. The AES-404 is intended for use for any application where it is desired to switch AES formatted signals and for standard audio formats decode to analog L/R output. Uses include studio or transmitter audio source switching or for virtually any digital switching, distribution and/or D/A conversion application. As shipped from the factory the unit is supplied with XLR balanced connectors. The front panel contains all of the buttons for controlling the AES-404 including status indications and headphone confidence monitor. Remote control of the unit is possible via a general purpose I/O or via RS232/485 connection. For unbalanced use such as the 75 ohm unbalanced AES standard for digital audio transmission order part number AES-404-75 which is supplied with BNC connector I/O for all digital inputs and outputs.



I. Unpacking

Carefully inspect the unit after unpacking and make certain that no damage has occurred during shipping. If damage is noted, contact the shipper immediately and file a claim for damages. Each unit is carefully packed and carries full insurance against damage. Inspect the packing list and make sure that the contents of the package match those described on the packing list.

II. Installation and Connections

Select a space in suitable E.I.A. standard rack to locate the unit. Determine the local electrical power supply voltage. As supplied from the factory, your AES-404 is setup for 100 – 240 V.A.C. 50 - 60 Hz. No external adjustment for local power standards is necessary if power available conforms to the above rating. The AES-404 utilizes a switch mode power supply and automatically adjusts for local power entry. Make connections to the unit following good engineering practice. Supply power to the unit utilizing a three conductor grounded outlet. Do not lift the electrical ground to the unit at the power receptacle as this will result in a safety hazard. In the event of ground loops, lift the ground at the offending connection only. Make certain that the unit is afforded proper ventilation in the area of the top cover vent.

A. Digital Interface

The AES-404 inputs are balanced XLR connections conforming to the AES standard. The unit can also be supplied with BNC connectors for digital I/O. Each XLR connection is terminated at 110 ohms as per the standard. The balanced digital outputs are also XLR connections which provide 110-ohm transformer coupled source impedance as per the AES standard. To unbalance any input or output unbalanced termination adapters can be purchased from Broadcast Devices, Inc. Order P/N 75 – XLRM for inputs and P/N 75-XLRF for output connections. All BDI adapters utilize BNC female interface for application to 75 ohm BNC connectorized cabling if the unit has been supplied with XLR connectors.

B. Analog Interface

There is provided on the rear of the unit a left/right balanced analog output. This output is suitable for driving 600-ohm balanced lines and is short circuit protected. A headphone jack and volume control buttons are provided on the front panel of the unit for confidence monitoring of the incoming feed. XLR balanced outputs conform to + 4 dBm output referenced to – 20 dBFS digital output.

III. Features and Operation

The AES-404 Digital Audio System is designed to select one of four AES3 compatible feeds and route it to up to two balanced digital outputs. It also contains a high quality digital to analog converter providing a balanced left and right output. The unit features a front panel headphone output and volume control for easy confidence monitoring. The AES-404 provides indication of loss of clock or any error displayed on the front panel. Command of the switcher is performed manually at the front panel or remotely. Remote control of the unit is accessed through the rear panel 9 pin D connector for simple momentary closure or through the RS232/485 serial interfaces on the rear panel of the unit. For simple momentary ground closure to the appropriate pin selects channels and error reset. Status of channel selected and error flag is also available at this connector. Refer to the connection table 3 for connection information. The interface is compatible with open collector command.

IV. Initial Operating Set up

Attach input and output connections to the unit using the appropriate connector. Plug the remote control plug in and tighten the connector screws in place. You may select any or all of the error flag and/or silence sense switching which will command the switcher to switch to the alternate path. Refer to *AES-404 DIP Switch Programming Guide of Operation* on page 5 for switch options. Refer to the factory default section of the table for supplied switch conditions. If the default conditions are satisfactory for your intended use no further changes need to be made. In order to change the DIP SW 1, 2 settings remove the front panel by removing 1 - #4-40 Phillips head screw in of the top cover located in the front center of the cover and 4 - #6-32 front panel screws. The front panel can now be removed and the DIP switches located which are on the front panel PC board. Other error flags and the silence sense error are selected by placing the designated DIP switches to the on position. Once DIP switch positions are selected the unit is ready to be powered up for operation.

Initial Power Application

Upon initial power application the unit will indicate the last channel selected and the channel selected LED indicator will be lit or flashing which indicates audio level under threshold for at least 5 seconds. This feature allows the user to determine if audio level is sufficient to drive the unit or for troubleshooting purposes. This feature can be defeated if desired by setting DIP SW1-6 to the OFF position. In the OFF position the unit will always indicate channel selection with a steady lighted indication. There should also be an indication of sample frequency. The AES-404 supports any sample rate between 32 and 192 KHz. Standard sample rates are indicated on the front panel under "Sample Rate" and non-standard sample rates are indicated with the "OTHER" LED indication being illuminated. Press the error-reset button to clear any errors that might be indicated. If any of these errors occur after depressing the error-reset button, then the feed to the unit is defective and should be investigated. If all is in order, the unit is now ready for operation. All that is left to do is to select the desired feed. When in AUTO mode and an error occurs the unit will go to manual mode and the "MAN" button and error indication will flash to indicate that an

error has occurred. To clear the error, depress the “ERROR” button. If the error clears the “ERROR” button LED will extinguish, error indicators will extinguish and the “MAN” button will remain illuminated until the “AUTO” button is depressed.

Description of AES-404 Optional Programming Functions

S1-1 Front Panel Button Defeat – When set to on causes the A/B/C/D buttons to be non-operational. Rear panel GPIO and serial remote control are still available when this switch is turned on.

S1 -2 NA

S1-4, 5 Silence Detector Channel – Can be set to monitor both (L+R) or left only/right only. When set to both, the silence detector will switch to the alternate path if one or both channels signal level fall below threshold for the time delay set. For Left or Right only the silence sensor will only switch after the channel being monitored times out. The unselected channel is ignored.

S1-6 Silence Indication on A/B/C/D Buttons – Will cause the selected channel button to flash if audio level falls below threshold for more than 15 seconds. Set to off for steady on condition of A/B buttons.

S1-8 Serial Remote Control – Turns on serial remote control functionality.

S2-1 NA

S2-2 NA

S2-3

S2-5

S2-6 Audio Bit – If the digital audio stream audio bit is set to 0 which denotes non audio payload data this setting is set to on the analog output is muted.

S2-7 Non PCM Audio –Setting when non PCM audio streams are detected such as Dolby E and AC-3 formats. To use the switcher and digital DA for non PCM audio formats set S2-6, S2-7, S1-4 and S1-5 to off position.

AES-404 DIP Switch Programming Guide of Operation Table 1.

S1-1 OFF = Front Panel Button Disables A/B and AUTO/MAN Buttons - Factory Default – ON

Silence Sensor Time out Parameters:

S1-3	S1-2	Silence Timeout (SEC)
OFF	OFF	120
OFF	ON	90
ON	OFF	60
ON	ON	30 Factory Default

S1-4 Silence Detector L Channel - ON = Silence detection enabled

S1-5 Silence Detector R Channel - ON = Silence detection enabled

S1-6 Silence Indication on A/B Select buttons - ON = Enabled – Factory Default ON

S1-7 Unused

S1-8 Serial Control Enable - ON = Enabled - Factory Default ON

Digital Parameter Switch Selection:

S2-1 AES Error Switching Delay – Factory Default ON

S2-2 Unlock – ON - Factory Default ON

S2-3 Parity – ON -Factory Default ON

S2-4 - UNUSED -

S2-5 CRC

S2-6 Audio Bit

S2-7 Non-PCM Audio

S2-9

Remote Control – Parallel/GPIO DB9F Connection Table 2.

Pin 1 Source D Status

Pin 2 Source D Select

Pin 3 Source B Select

Pin 4 Source A Select

Pin 5 Source C Select

Pin 6 Status Common

Pin 7 Source B Status

Pin 8 Source A Status

Pin 9 Source C Status

Command input pins require a momentary closure to common. Status connections open collector outputs which require a 5 VDC pull up.

AES-404 REMOTE CONTROL

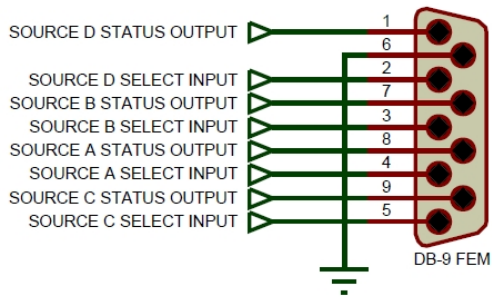

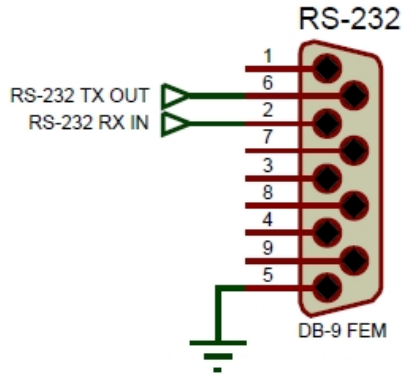

Remote Control RS-232 Connection Diagram

V. Specifications

Digital Inputs:	Four – XLR or BNC, model dependent
Digital Outputs:	Two – XLR or BNC, model dependent
Analog Output:	Balanced L/R XLR + 4 dBm 600 Ohms – Rear Panel
Headphone out:	600 Ohm unbalanced - Front Panel
Sample Rate Range:	8 – 192 KHz, Auto Detect and Lock
D/A Converter Resolution:	Up to 24 bits
Remote Control:	Momentary ground closure selects channels and reset to auto mode operation or RS-232/485 Serial
Remote Status:	Channel Select Open Collector Output
Remote Control Connectors:	DB9F throughout
Front Panel Controls:	7 - Momentary Push buttons - Switcher Selection, Error Reset, Volume Up/Down
Front Panel Indicators:	Sample Rate, Lock Loss, Error Flags, Channel Status
Power Requirements:	100 - 240 V.A.C. @ 0.25A; 50 – 60 Hz.
Operating Environment:	0 – 60 Degrees Celsius Non Condensing Atmosphere
Physical:	19"W X 8"D X 1.75"H Mounted via Standard E.I.A. 19" rack one rack unit occupied. Weight: 8 LBS

FCC Certification Statement:

This device complies with Part 15 of the FCC Rules. Operation is subject to the following two conditions: (1) this device may not cause harmful interference, and (2) this device must accept any interference received, including interference that may cause undesired operation.

VI. Warranty

Broadcast Devices, Inc. products are warranted against failure due to faulty materials or workmanship for a period of one year from the date of shipment from Broadcast Devices, Inc. dock. The warranty covers repair or replacement of defective parts at the factory, provided the unit has been returned prepaid by the user. All shipments to the factory shall have affixed to the outside of the container a return authorization number obtained from the factory. The above warranty is void if the unit has been modified by the user outside of any recommendations from the factory or if the unit has been abused or operated outside of its electrical or environmental specifications. If customer conducted field tests suggest that the unit may be faulty, whether or not the unit is in warranty, a full report of the difficulty should be sent to Broadcast Devices, Inc. factory. The factory may suggest further tests or authorize return for factory evaluation. Please email: customer.service@broadcast-devices.com

Units sent to the factory should be well packed and shipped to Broadcast Devices, Inc. – Check www.broadcast-devices.com for current shipping address. Remember to affix the R.A. number to the outside of the carton. Any packages received without such R.A. number will be refused. Note: freight collect shipments will also be refused. When the unit has been received, inspected and tested, the customer will receive a report of the findings along with a quotation for recommended repairs, which are found falling outside of the standard warranty. Units returned for in-warranty repairs, which are found not to be defective will be subject to an evaluation and handling charge. In-warranty units will be repaired at no charge and returned via prepaid freight.

Out-of-warranty units needing repair require a purchase order and will be invoiced for parts, labor, and shipping charges.

When ordering replacement part, always specify A) Part Description, and Quantity; B) Date of Purchase, Where Purchased; C) Any Special Shipping Instructions. Always specify a street address, as shipping companies cannot deliver to a postal box.

Broadcast Devices, Inc. is not responsible for any other manufacturer's warranty on original equipment. Nor are we responsible for any failure, damage, or loss of property that may occur due to the installation or operation of our equipment outside of recommended specifications.

Broadcast Devices, Inc. reserves the right to change materials, specifications, and features from time to time. www.broadcast-devices.com

Tel. (914) 737-5032 Facsimile: (914) 736-6916

Email: Customer.service@broadcast-devices.com