



Broadcast Devices, Inc.

# Passive 8/16 2X1 Switcher

TECHNICAL REFERENCE MANUAL

Broadcast Devices, Inc.  
2066 E. Main Street  
Cortlandt Manor, NY 10567  
Tel. (914) 737-5032  
Fax. (914) 736-6916

REV: B 11/09

## **Table of Contents**

### **The 8/16 2X1 Passive Switcher**

- I. Introduction**
- A. Unpacking and Inspection**
- B. General Description**
- II. Specifications**
- III. Installation**
- A. Initial Configuration**
- B. Location and Hookup Considerations**
- C. Remote Control/Status Connection**
- IV. Warranty**
- V. Schematic Diagrams**
- A. Overall Schematic**

## I. Introduction

The 8/16 Switcher series are an 8 or 16 input 2 by 1 passive switchers. The 8/16 series are capable of accepting up to two or four sets of balanced inputs and switching them to a single or dual set of up to 8 outputs. The signal path is completely passive using latching relays. Front panel and remote control of the unit is possible. Local status is provided by lights on the front panel and remote status is provided via dry contact closure on the remote control connector. The unit requires only a momentary connection to ground on the appropriate pin for switcher operation.

### A. Unpacking and Inspection

Carefully unpack the unit after receipt and inspect for damage that may have occurred during shipping. If damage is noted, contact the shipper immediately and file a damage claim. The contents of the package have been insured to cover total replacement cost. Make certain that the package contents are the same as noted on the packing slip. If not, contact Broadcast Devices, Inc. Check to make sure all mechanical parts are secure. Units are delivered from the factory configured for 120 volts A.C. 60 Hz. Operation. Check to make sure that the power source is correct for proper operation. Units are field configurable for 240 Volt operation. See initial configuration section of part III, installation section for different power configuration.

### B. General Description

The 8/16 series switchers can accept as many as two sets of 8 or 16 monaural balanced inputs which can be selected to a single or dual set of 8 outputs. By use of magnetically latching relays the unit is completely passive to the signal path. Power interruption will cause the relays to deenergize to the "A" position. When power is restored the unit will restore connection to whichever position the unit was in before power interruption.

## II. Specifications

Input Connectors:	DB25
Output Connector:	DB25
Remote Control Connector	DB25
Number of A/B inputs	8 balanced for 8 Channel unit 16 for 16 channel unit
Power Requirements:	100 - 240 Volts A.C. 50 - 60 Hertz
Operating Temperature Range:	0 - 60° Celsius non condensing atmosphere
Physical Dimensions:	1.75 H X 19 W X 10 D (inches)

## Installation

### A. Initial Configuration

The unit as configured from the factory is set to accept 100 to 240 Volts A.C. 50 - 60 Hertz electrical power. No changes are necessary to change voltage selection.

### B. Location and Hookup Considerations

Locate the 8/16 in a 19-inch E.I.A. standard rack enclosure in close proximity to the equipment that it is going to interface between. Allow sufficient airflow space between equipment to allow for proper cooling. Make all desired input and output connections to your external equipment using the pin out provided for the DB25 connectors. An optional DB25 to XLR breakout cable is

available from bdi. Call us for more information about availability and pricing. Make sure that the 8/16 is plugged in to a properly grounded A.C. receptacle.

### C. Remote Control/Status Connection

Refer to the table below for remote control and status connections. The 8/16 requires a momentary ground closure for switching operation. The 8/16 can accept an open collector output for this purpose or a simple relay closure will actuate a switching function. Status provided is a set of dry contacts offering NO/C/NC connection to remote control equipment.

#### Remote Control Status Table

Pin 1 K1 COM  
Pin 2 K1 NO  
Pin 3 K2 NC  
Pin 4 No Connection  
Pin 5 No Connection  
Pin 6 No Connection  
Pin 7 No Connection  
Pin 8 Select A Command – Momentary to ground  
Pin 9 Select B Command – Momentary to ground  
Pin 10 No Connection  
Pin 11 No Connection  
Pin 12 No Connection  
Pin 13 No Connection  
Pin 14 K1 NC  
Pin 15 K2 COM  
Pin 16 K2 NO  
Pin 17 GND  
Pin 18 GND  
Pin 19 GND  
Pin 20 GND  
Pin 21 GND  
Pin 22 GND  
Pin 23 + 5VDC  
Pin 24 + 5VDC  
Pin 25 No Connection

#### **IV. Warranty**

Broadcast Devices, Inc. products are warranted against failure due to faulty materials or workmanship for a period of one year from the date of shipment to the ultimate user. The warranty covers repair or replacement of defective parts at the factory, provided the unit has been returned prepaid by the user. All shipments to the factory shall have affixed to the outside of the container an R. A. number obtained from the factory. The above warranty is void if the unit has been modified by the user outside of any recommendations from the factory or if the unit has been abused or operated outside of its electrical or environmental specifications. If customer conducted field tests suggest that the unit may be faulty, whether or not the unit is in warranty, a full report of the difficulty should be sent to Broadcast Devices, Inc. factory at Cortlandt Manor, New York. The office may suggest further tests or authorize return for factory evaluation.

Units sent to the factory should be well packed and shipped to Broadcast Devices, Inc. 2066 E. Main Street, Cortlandt Manor, NY 10567. Remember to affix the R.A. number to the outside of the carton. Any packages received without such R.A. number will be refused. Note: freight collect shipments will also be refused. When the unit has been received, inspected and tested, the customer will receive a report of the findings along with a quotation for recommended repairs, which are found falling outside of the standard warranty. Units returned for in-warranty repairs which are found not to be defective will be subject to an evaluation and handling charge. In-warranty units will be repaired at no charge and returned via prepaid freight.

Out-of-warranty units needing repair require a purchase order and will be invoiced for parts, labor, and shipping charges.

When ordering replacement part, always specify A) Part number or Description, and Quantity; B) Date of Purchase, Where Purchased; C) Any Special Shipping Instructions. Always specify a street address, as shipping companies cannot deliver to a postal box.

Broadcast Devices, Inc. is not responsible for any other manufacturer's warranty on original equipment. Nor are we responsible for any failure, damage, or loss of property that may occur due to the installation or operation of our equipment outside of recommended specifications.

## V. Schematic Diagrams

### A. Schematic Diagram

## **V. Schematic Diagrams**

### A. Schematic Diagram

**FROM FRONT PANEL**

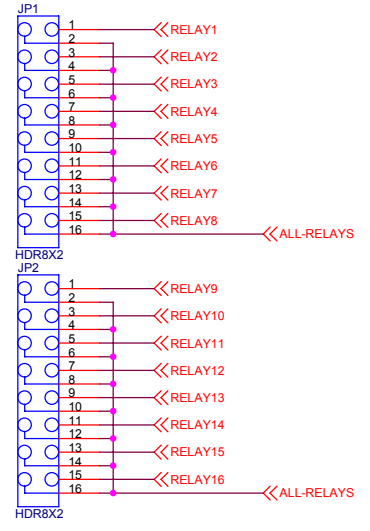
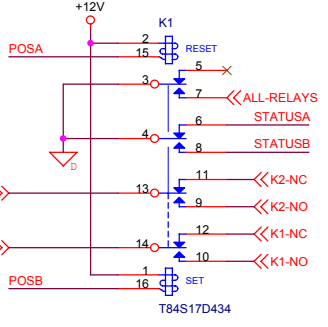
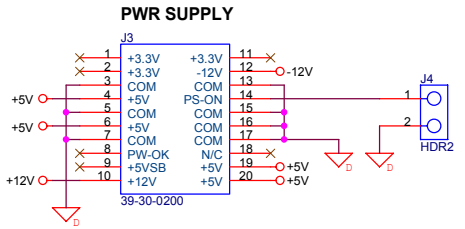
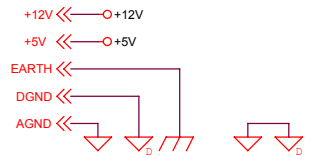
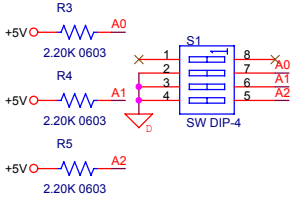
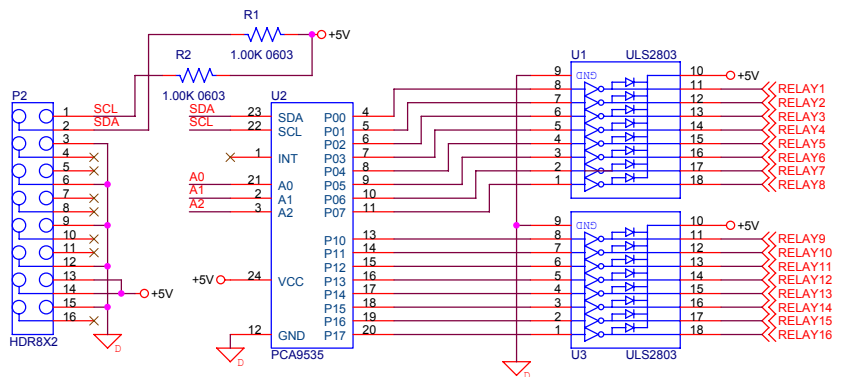

**FROM FRONT PANEL**

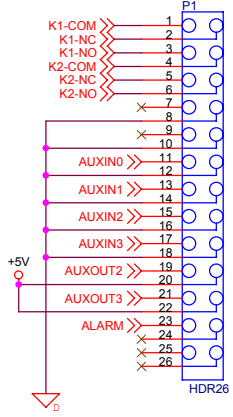

**REMOTE DB-25**

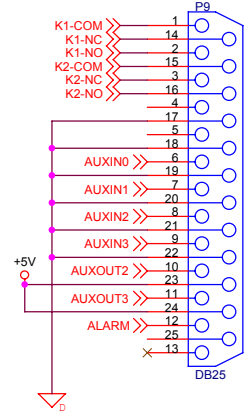

**BUTTON BOARD**

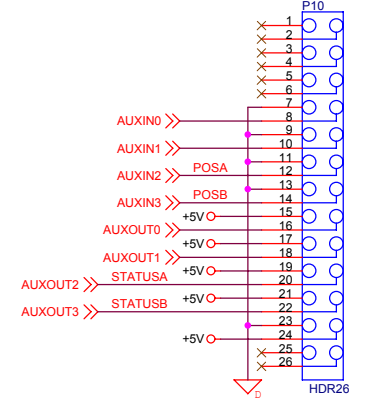

<b>Broadcast Devices, Inc.</b>		
Title AUDIO SWITCH CONTROL		
Size B	Document Number	Rev A
Date: Tuesday, August 14, 2007	Sheet 1	of 3



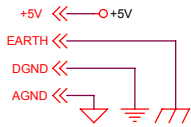
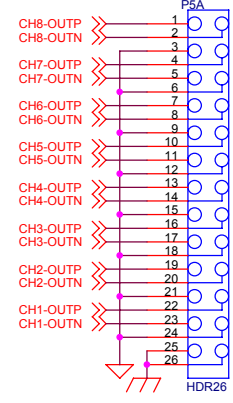
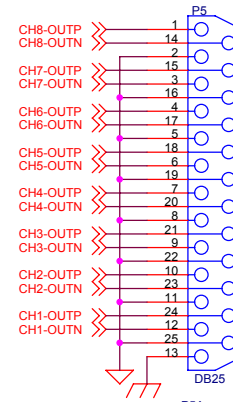
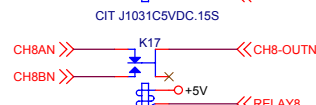
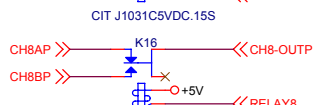
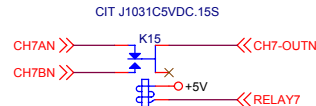
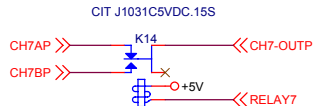
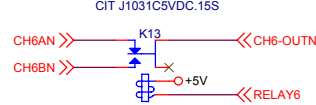
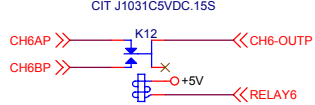
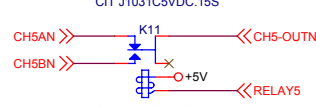
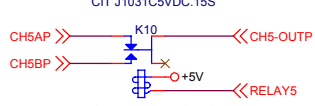
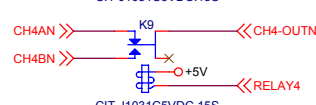
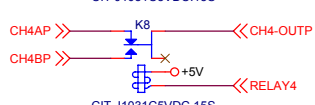
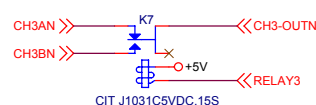
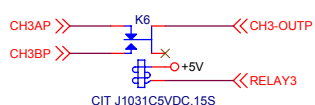
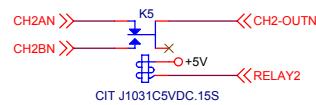
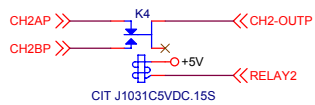
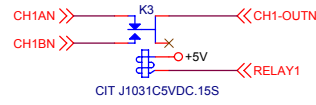
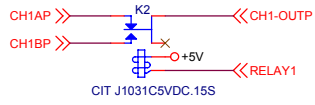
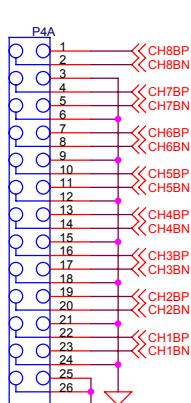
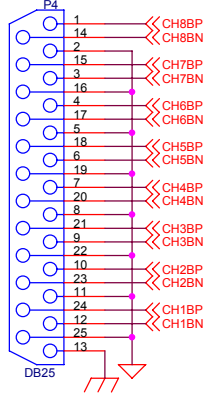
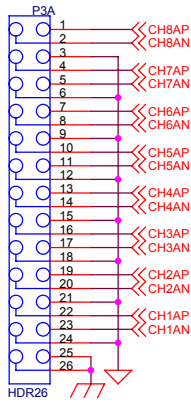
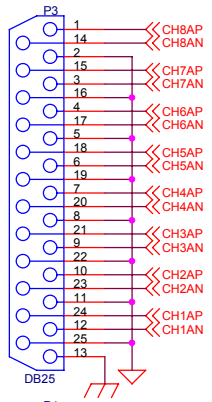

<b>Broadcast Devices, Inc.</b>		
Title AUDIO SWITCH CHAN 1-8		
Size B	Document Number	Rev A
Date: Tuesday, August 14, 2007	Sheet 2	of 3