

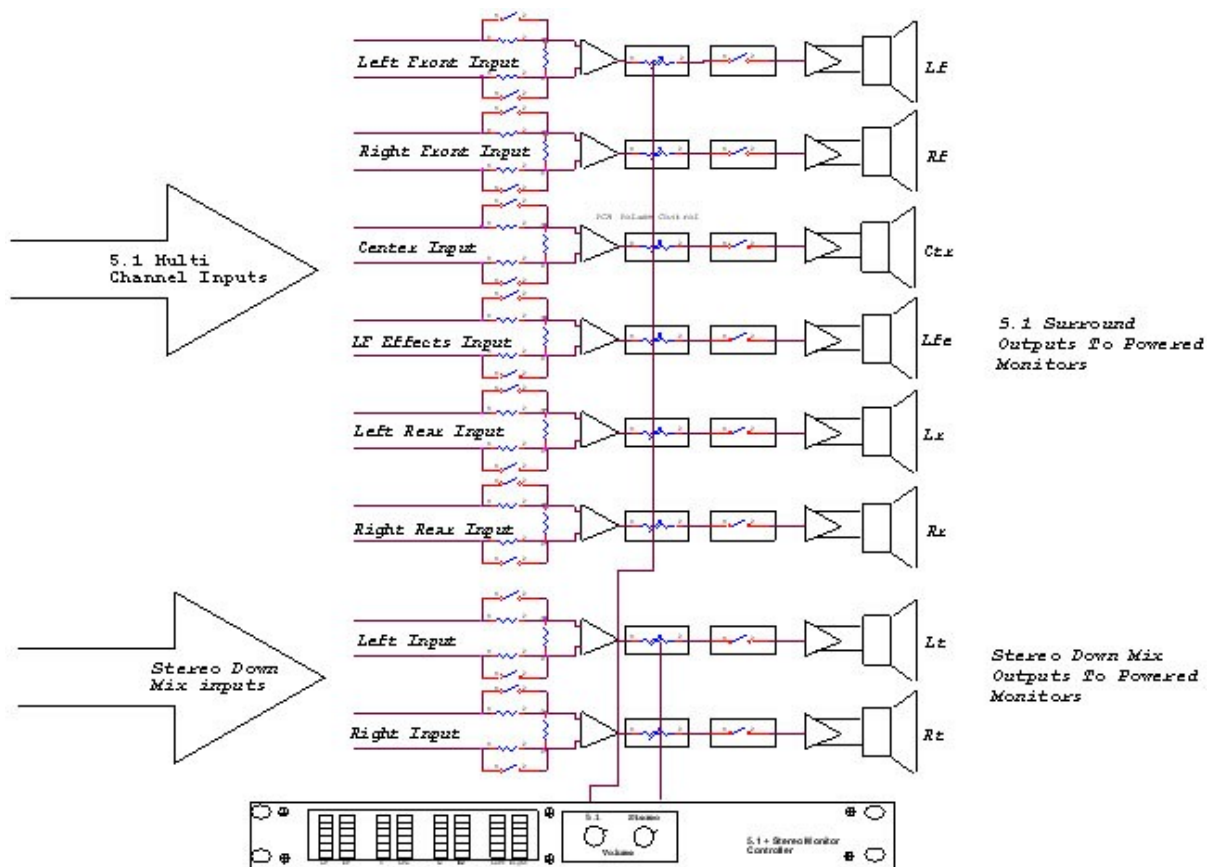

5.1 Plus Stereo Monitor Controller
5.1 Surround Control Made Simple
SURROUND SOUND PROBLEM SOLVER

5.1 Plus Surround & Stereo Monitor
Data sheet



Broadcast Devices, Inc.
 Tel. (914) 737-5032 Fax.. (914) 736-6916
 Visit us on the web at: www.Broadcast-Devices.com

5.1 + Stereo Monitor Specifications

Number of Channels:	8 Balanced I/O
Input Sensitivity:	-55 dBm Microphone Level or +4 dBm Line level selectable any channel
Output Level:	+4 dBm Balanced
Frequency Response:	+/- .2 dB from 20 Hertz to 20 KHz
Total Harmonic Distortion:	Less than .05% at +4 dBm output
System Noise:	-64 dB below +4 dBm output for microphone level sensitivity, -70 dB below +4 dBm output for +4 dBm input
Level Control:	2 - Front panel global 5.1 and separate stereo control all VCA controlled, optional remote control panel for individual channel volume control
Metering:	8 – Individual 10 Segment LED VU Meter displays Lf, Rf, C, Lfe, Lr, Rr, - 5.1 and L, R Stereo
Audio I/O connector:	DB25 conforms to Tascam® D-88 connector standard – optional XLR breakout panels available
Remote Control:	8 individual level controls, individual or global mute, and global dim -10, 20 or 30 dB – REM-400 remote control panel available
Power Requirements:	100 – 240 VAC 50 – 60 Hertz @ 0.2 Ampere
Physical Dimensions:	19" W X 1.75" H X 10" D Standard E.I.A. Single Rack Unit
Environmental	0 – 60 degree C. Non condensing atmosphere



Broadcast Devices, Inc.

Tel. (914) 737-5032 Fax.. (914) 736-6916

Visit us on the web at: www.Broadcast-Devices.com